

Panasonic

BUSINESS

For Panasonic Robot
TAWERS TS/TM/TL/LA
**Positioners
&
Peripherals**

Fine Combination

Large Selection of Positioners and Peripherals
for Better and Faster TAWERS Welding

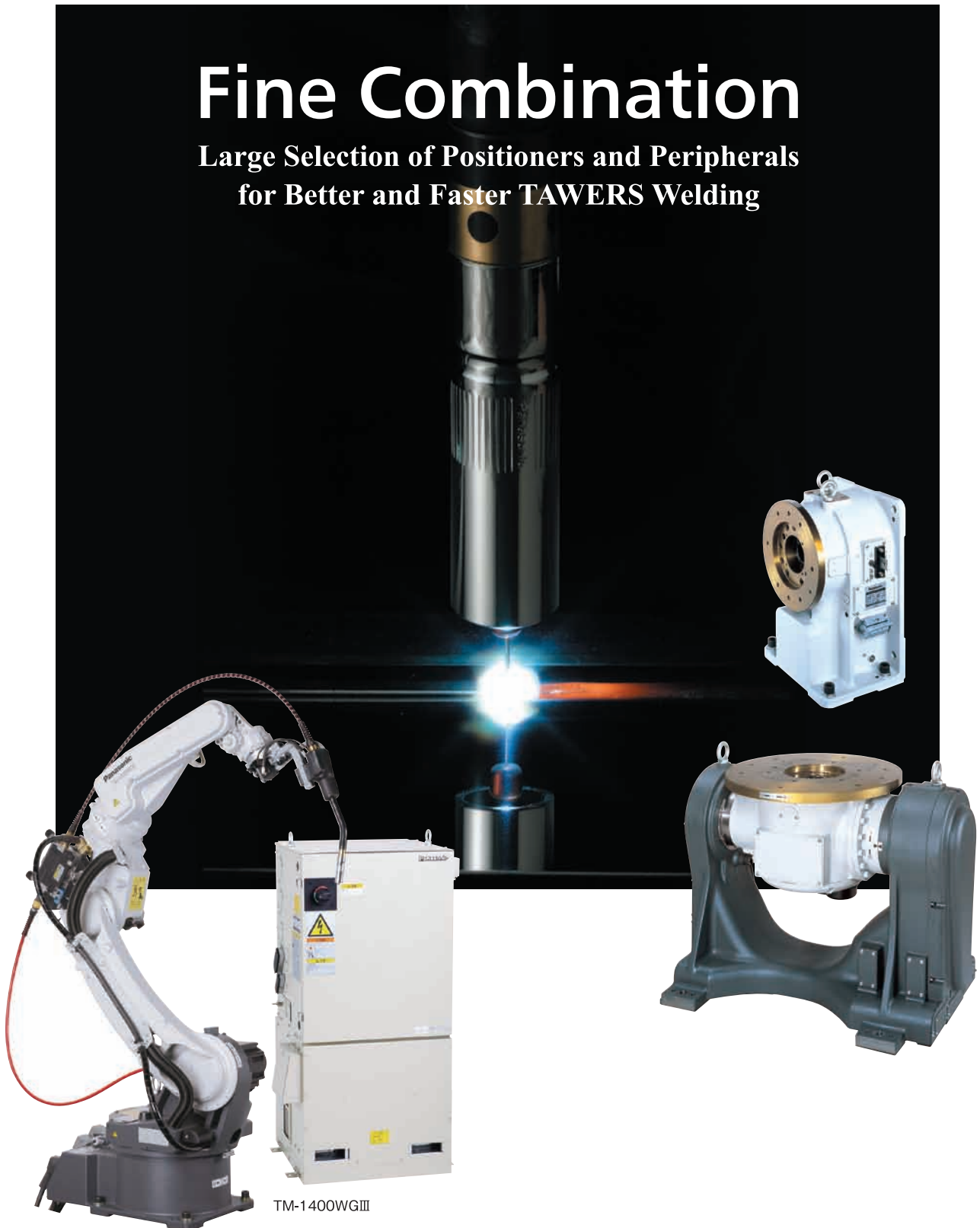

TM-1400WGIII

Positioners R series

Achieved better welding quality, faster welding speeds and smaller footprint of the robotic welding.

Single-axis positioners

Side mount 2-axis positioners



Payload:
250/500 kg

RJB 12/22



Payload:
1 000 kg

RJB 32

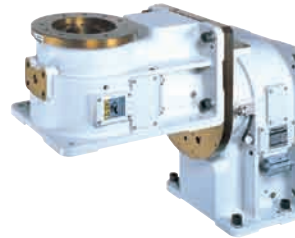

RJR 42

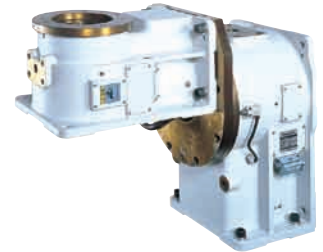

RJR 52

<Features>

- **Best-in-class motion speed**
Maximum speed is twice that of conventional models. (1 000 kg type)
- **Slim design allows compact welding system**
Depth is about 30 % smaller than conventional models. (500 kg type)
- **Space-saving cable connection method**
Cable protruding length is less than half of conventional models. (120 mm)
Connection to the other side is available as an option.
- **Dust proof construction and large hollow shaft diameter**
φ75 mm (1 000 kg type), φ55 mm (500/250 kg type)

■ Outside dimensions

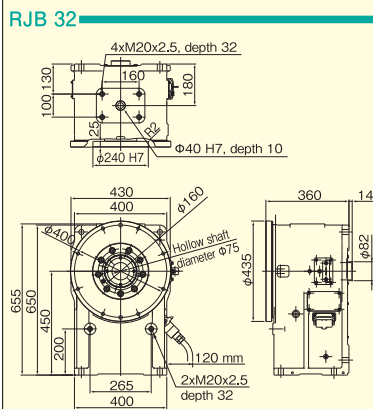
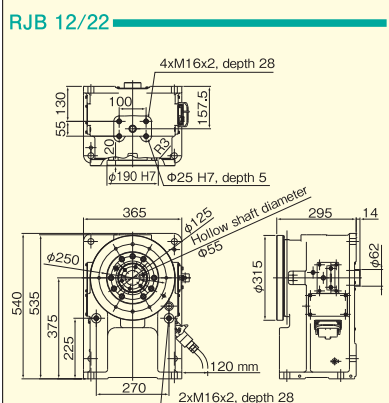

■ Specifications

Name	Positioner unit		
	YA-1RJB12Y**	YA-1RJB22Y**	YA-1RJB32Y**
Model	YA-1RJB12Y**	YA-1RJB22Y**	YA-1RJB32Y**
Applicable robot	TS/TM/TL/LA-WGⅢ/GⅢ robot systems		
Payload	250 kg	500 kg	1 000 kg
Maximum output speed	190°/s (30 r/min)	120°/s (16 r/min)	120°/s (20 r/min)
Operating range	±10 revolutions (with multi-rotation data reset function)		
Allowable rotational torque	196 N·m	490 N·m	1 470 N·m
Allowable moment	1 470 N·m	1 470 N·m	6 125 N·m
Repeatability	±0.05 mm (R=250)		
Diameter of hollow shaft	55 mm (diameter)	55 mm (diameter)	75 mm (diameter)
Brake	Provided		
Allowable welding current	500 A at 60 % duty cycle		
Weight	125 kg		255 kg
Applicable welding processes	CO ₂ /MAG/MIG/TIG		
External axis controller types	Internal/External		External

■ Support units

- YA-1RJS21: 500 kg payload and the same outside dimensions as RJB 12/22
- YA-1RJS31: 1000 kg payload and the same outside dimensions as RJB32

RJR 42

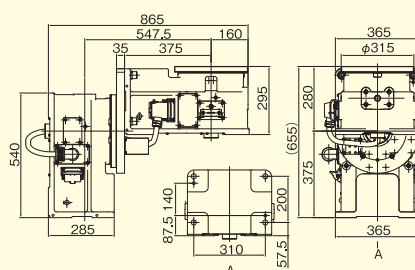

RJR 52

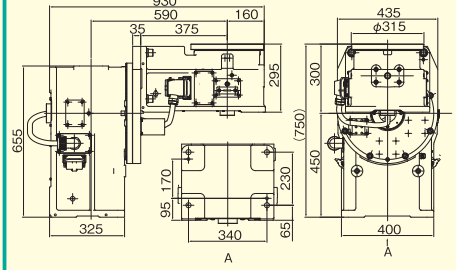

Center mount tilt rotate positioner High speed type **R series**



Two types available with payloads of 300 and 500 kg

Specifications

Name		Positioner unit	
Model		YA-1RJ062Y**	YA-1RJ072Y**
Applicable robot		TS/TM/TL/LA-WGIII/GIII robot systems	
Payload		300 kg	500 kg
Maximum output speed	Rotational	190.0°/s (31 r/min)	165.0°/s (27 r/min)
	Tilt	125.5°/s (20 r/min)	90.0°/s (15 r/min)
Operating range	Rotational	±10 revolutions (with multi-rotation data reset function)	
	Tilt	-135° to +135°	
Allowable moment	Rotational	323 N·m	392 N·m
	Tilt	882 N·m	1 274 N·m
Repeatability		±0.05 mm (R=250 mm)	
Diameter of hollow shaft		55 mm (diameter)	
Allowable welding current		500 A (Duty cycle: 60 %)	
Weight		285 kg	
Applicable welding processes		CO ₂ /MAG/MIG/TIG	
External axis controller types		Internal/External	

●80 % faster maximum speed compared with conventional model.

●Smallest footprint (780 x 500 mm) in the class. (300 kg type)

●Easier installation with three selectable cable outlet positions.

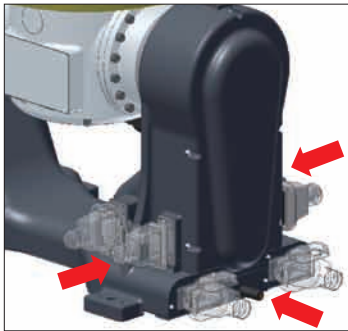

Outside dimensions

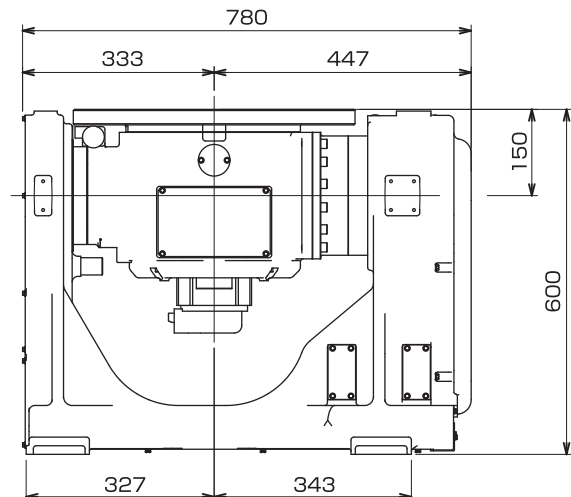
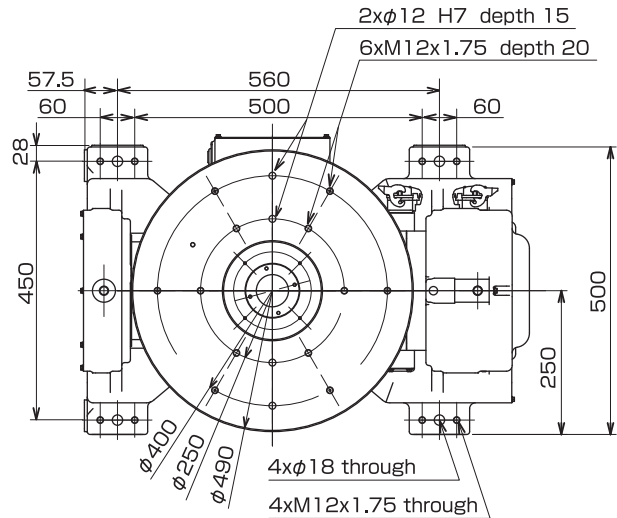
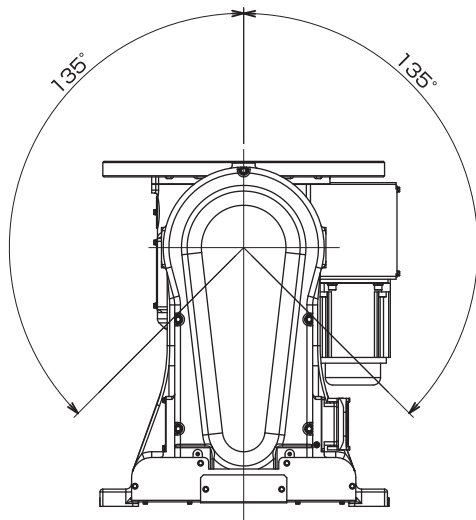

Motor units

■ 7 models from 100 W to 5 500 W

Model No.	APU01246	APU01271	APU01247	APU01248	APU01249	APU01250	APU01251
Rated output (W)	100	200	750	1 600	2 000	3 500	5 500
Rated torque (N·m)	0.318	0.64	2.39	5.09	9.54	16.6	26.0
Instantaneous maximum torque (N·m)	0.95	1.91	7.16	15.27	28.5	50.0	52.9
Rated rotation (r/min)	3 000	3 000	3 000	3 000	2 000	2 000	2 000
Maximum rotation (r/min)	6 000	6 000	5 000	5 000	3 000	3 000	3 000



Internal controller for external axes (WGⅢ/GⅢ)

Model No.	YA-1VPAP1***	
Number of controllable external axes	Up to 3 axes (simultaneous control)	
Maximum applicable motor capacity	Per axis	2 kW or lower
	Total capacity	6 kW or lower
Applicable robot	TS/TM/TL/LA-WGⅢ/GⅢ series	
Applicable external axes	Positioner unit	YA-1RJB12, YA-1RJB22 YA-1RJR42, YA-1RJC62 YA-1RJC72
	AC servo motor unit	APU01246, APU01247 APU01248, APU01249 APU01271
	Rotary TIG filler unit	YA-1YK3T1T00 (Only TL-1800 type manipulator)

*** depends on the combined external axis.

■ Example of connections to GⅢ controller

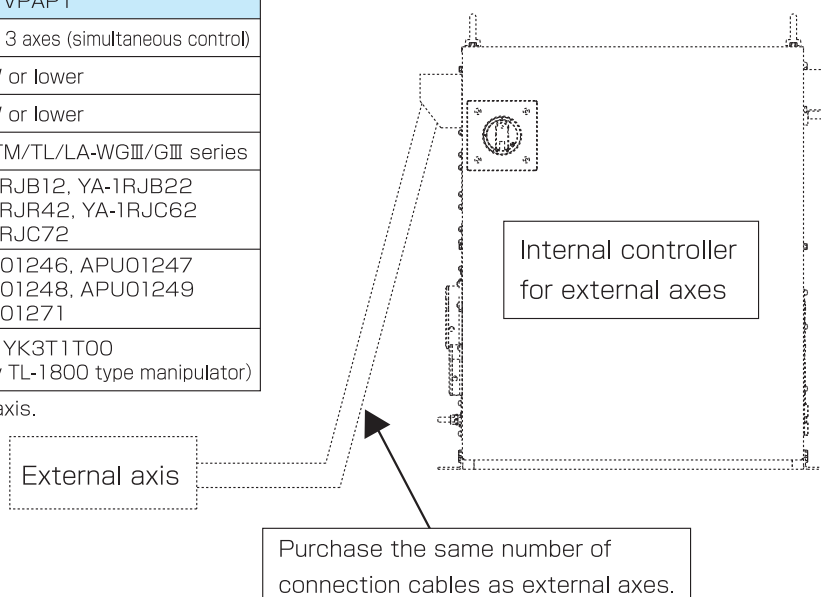

External controller for external axes (WGⅢ/GⅢ)

Model No.	YA-1VPA□1***	
Number of controllable external axes	Up to 6 axes (simultaneous control)	
Maximum applicable motor capacity	Per axis	5.5 kW or lower
	Total capacity	20 kW or lower
Applicable robot	TS/TM/TL/LA-WGⅢ/GⅢ series	
Applicable external axes	Positioner unit	YA-1RJB12, YA-1RJB22 YA-1RJB32, YA-1RJR42 YA-1RJR52, YA-1RJC62 YA-1RJC72
	AC servo motor unit	APU01246, APU01247 APU01248, APU01249 APU01250, APU01251 APU01271
	Rotary TIG filler unit	YA-1YK3T1T00 (Only TL-1800 type manipulator)
Dimensions (WxDxH)	553 x 550 x 400 (mm)	

□ depends on the number of external axis.
(1: K, 2: A, 3: L, 4: B, 5: M, 6: C)

*** depends on the combined external axis.

■ Example of connections to GⅢ controller

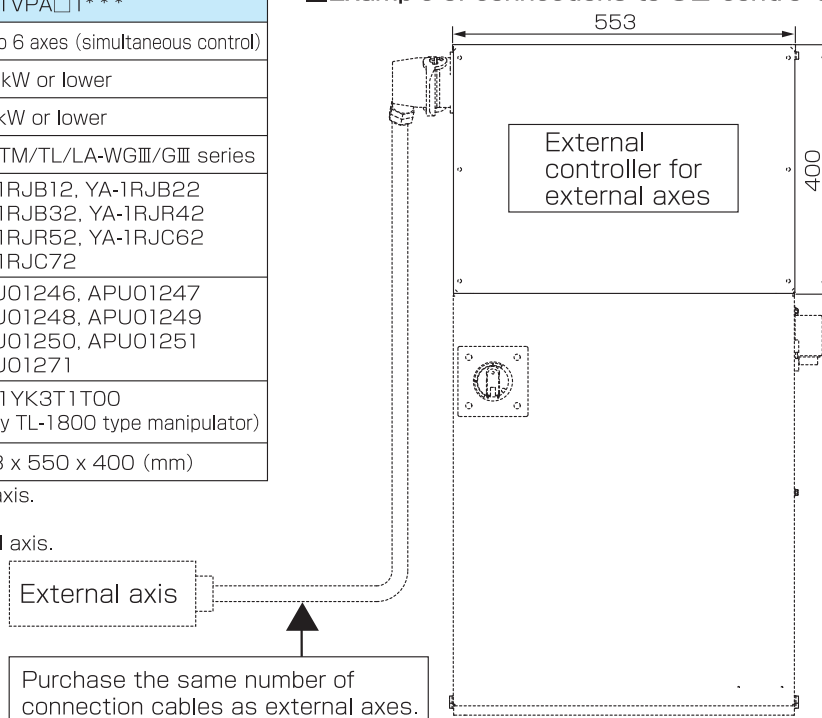

(Independent amplifier type) External controller for external axes (WGIII/GIII)

■ Servo off function for each axis ensures safety.

■ Connection example to GIII controller

Model No.		YA-1VPA□2***
Number of controllable external axes		Up to 6 axes (simultaneous control)
Maximum applicable motor capacity	Per axis	5.5 kW or lower
	Total capacity	20 kW or lower
Applicable robot		TS/TM/TL/LA-WGIII/GIII series
Applicable external axes	Positioner unit	YA-1RJB12, YA-1RJB22 YA-1RJB32 YA-1RJR42, YA-1RJR52 YA-1RJC62, YA-1RJC72
	AC servo motor unit	APU01246, APU01247 APU01248, APU01249 APU01250, APU01251 APU01271
	Rotary TIG filler unit	YA-1YK3T1T00 (Only TL-1800 type manipulator)
Dimensions (WxDxH)		553 x 579 x 502 (mm)

□ depends on the number of external axes.
(1: K, 2: A, 3: L, 4: B, 5: M, 6: C)

*** depends on the combined external axis.

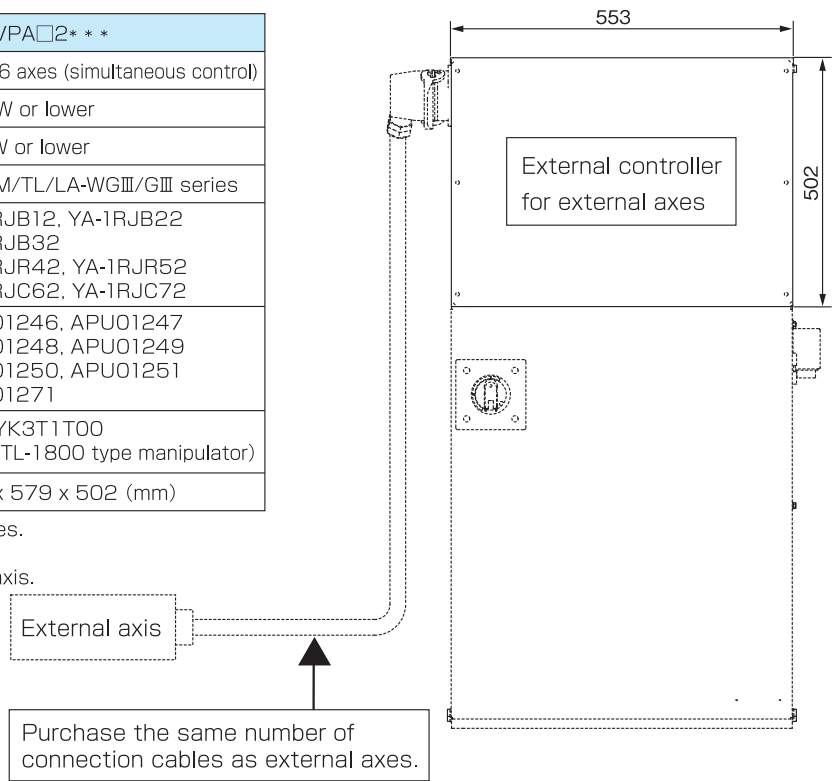

(Optional) External axis connection cables (WGIII/GIII)

● Standard external axis connection cables

● External axis extension connection cables

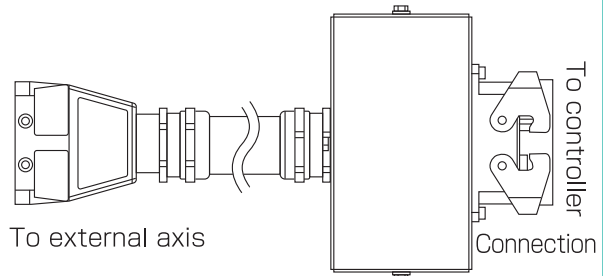
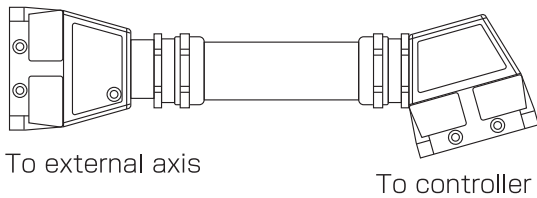

Description	Length	Model No.
Standard external axis connection cables (Cannot be used for 5.5 kW motor type and TIG filler rotary unit)	6 m	AWU03879L6M
	8 m	AWU03879L8M
	10 m	AWU03879L10M
	12 m	AWU03879L12M
	16 m	AWU03879L16M
	20 m	AWU03879L20M
	24 m	AWU03879L24M
	30 m	AWU03879L30M
5.5 kW motor type connection cables	6 m	AWU03892L6M
	8 m	AWU03892L8M
	12 m	AWU03892L12M
	16 m	AWU03892L16M
	20 m	AWU03892L20M
	24 m	AWU03892L24M
30 m	AWU03892L30M	
TIG filler rotary unit connection cable	6 m	WSAWU010LPZZ

Description	Length	Model No.
External axis extension connection cables (Cannot be used for 5.5 kW motor type and TIG filler rotary unit)	4 m	WSAWU003LMZZ
	6 m	WSAWU003LPZZ
	8 m	WSAWU003LRZZ
	10 m	WSAWU003LTZZ
	12 m	WSAWU003LVZZ
	14 m	WSAWU003LXZZ
	20 m	WSAWU003MDZZ

Notes:
 · All the cables are flexible type.
 · The extension cables can only be used with the connection cables.

Notes:
 · All the cables are flexible type.
 · The maximum cable length is 30 m including the extension cable.
 · The 5.5 kW motor type connection cables and the TIG filler rotary unit connection cable cannot be extended.

Harmonizer

Simple teaching

Teaching example of complicated workpiece

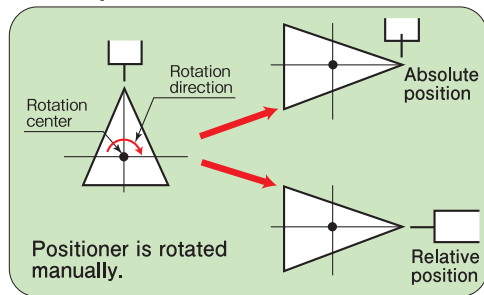

Easy welding speed setting.

Welding speed can be set directly from robot regardless of pipe diameters. It eliminates complicated calculation and reduces teaching time.

Greatly reduced teaching points. (compared with conventional systems)

Linear, circular interpolations, and weaving movement are now available while rotating work with the positioner. This allows easy torch positioning for complicated workpieces and high precision welding with minimum teaching points.

Optimum welding position.

Optimum torch angle for the best bead shape is ensured by specifying the torch position to the workpiece from either absolute or relative position.

Easy system settings.

System can be set on site and adjustable by the user.

DTPS III Desk Top Programming & Simulation system

DTPS is a program simulation software developed exclusively for Panasonic robots. With this software, users can create and edit robot programs and verify robot motion offline.



<Features>

- Useful edit function (batch conversion, shifting, etc.)
- Highly-accurate movement simulation
- 3D graphics
- Identical to robot operation
- Simple CAD function for workpiece shape creation
- Graphic import function (standard)
- Multiple robot control ● Windows 8.1 / Windows 10



Wire Booster

Easy adjustment of wire feeding power and pressure on the wire



Good for stable feed of thin wire

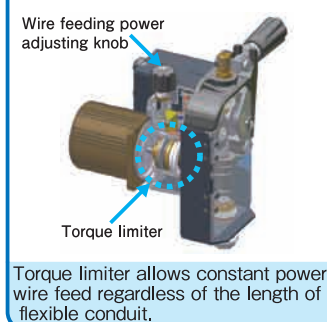

Specifications

Model No.	YW-PCF041E00
Rated input voltage, number of phases	230 V, Single phase
Frequency	50 Hz
Rated input	38 VA
Applicable wire materials	Mild steel, Stainless steel, FCW, Aluminum
Applicable wire diameters	Mild steel, Stainless steel, FCW: 0.8 mm to 1.6 mm Aluminum: 1.2 mm, 1.6 mm 1.0 mm hard aluminum wire can only be used for TAWERS Pull MIG type.
Input start signal	DC24 V±3.6 V, 20 mA or more
Dimensions (WxHxD)	202 mm x 190 mm x 201 mm
Weight	4 kg



We provide products that are friendly to the environment.

As an earth-friendly company, Panasonic Corporation discourages the use of hazardous substances in our products. The products of Panasonic Corporation comply with the European RoHS directive.

Safety precautions ● Before attempting to use any welding product always read the manual to ensure correct use.

Panasonic Corporation

Process Automation Business Division, Process Innovation Center
1-1,3-chome,Inazu-cho,Toyonaka,OSAKA 561-0854 Japan
TEL:81-6-6866-8505 FAX:81-6-6866-0709

Panasonic Smart Factory Solutions Co., Ltd.

<https://www.panasonic.com/jp/company/psfs.html>

Panasonic Welding Systems (Tangshan) Co., Ltd.

No.9 Qingnan Rd.,Tangshan New & Hi-Tech Industrial Park,
063020 Hebei, China
TEL: 86-315-320-6060 FAX: 86-315-320-6070
<http://pwst.panasonic.cn>

Panasonic Smart Factory Solutions India

Industrial Plot No.1, Village Bid Dadri, Jhajjar - 124103,
Haryana, India

Panasonic System Solutions Company of North America

1701 Golf Road, Suite 3-1200 Rolling Meadows, IL 60008 USA
TEL: 1-847-637-9700 FAX: 1-847-637-9601
<http://www.panasonicca.com>

Panasonic Industry Europe GmbH

Jagenbergstr 11a, D-41468 Neuss Germany
TEL: 49-2131-60899-0 FAX: 49-2131-60899-200
<http://eu.industrial.panasonic.com/>

Panasonic Industrial Devices Sales(Thailand) Co.,Ltd.

252/133 Muang Thai-Phatra Complex Building, 31st Fl.
Rachadaphisek Rd., Huaykwang, Bangkok 10320 Thailand
TEL: 662-693-3421 FAX: 662-693-3427

● Specifications are subject to change without notice.

● Windows is a registered trademark of Microsoft Corporation in the United States and other countries.

Catalog No. IRPOSI-R

Printed in Japan [2020.1] 8-001U