



TOGGLE CLAMPS AND LATCHES



See the New Secure-Lock Latch Clamps, pgs. 28-34

Distributed by:

www.goodhandinc.com

QUALITY • DIVERSITY • ECONOMY



— DRIVEN BY CUSTOMER DEMAND —

For over 45 years, we've served our valued, worldwide customers by providing clamps that are built to suit a wide variety of industrial and OEM applications. Because whether you need a clamp to push, pull, hold down, lock, position, or tighten, we'll either help you find exactly what you need in our catalog, or we'll modify one of our standard clamps to your exact specifications, or we'll custom-build a clamp for you!

Our caring, highly skilled staff is devoted to helping you design a system that will solve both the ordinary and repetitive, and the unique and situational work-holding needs. With vertical, horizontal, and push/pull action, toggle clamps offer the flexibility to provide solutions in manufacturing, assembly, storage, machine building, and shop use.

We manufacture over 350 models of toggle clamps, and our new product development is ongoing and is driven by customer demand. We pride ourselves on featuring a line of clamps that offers more variety than the competition, and we are continually seeking new designs to fill a need that has not yet been met. We react to you, our valued customers, with urgency and sincere interest in meeting your requirements. We remain driven to satisfy, driven to deliver a clamping line that exceeds your expectations in quality, diversity, and economy.

Please contact us and tell us how we can best serve you...

CUSTOMER SERVICE : 800.989.5244
WWW.GOODHANDINC.COM

Good Hand, Inc.
8750 Pioneer Blvd.
Santa Fe Springs, California 90670 U.S.A.
Tel : 562.949.8625
Fax : 562.949.4875
E-Mail: sales@valtrainc.com

GOOD HAND™ QUALITY ASSURANCE

- All die-stamped steel parts are deburred, cleaned, and zinc-plated for a finish that resists corrosion and creates a smooth, easy to clean surface.
- Toggle mechanism designed to allow maximum clearance for ease of loading and unloading work-pieces.

Flanged Washers are supplied with all U-bar and open bar models. Bolt retainers are supplied with all solid bar models.

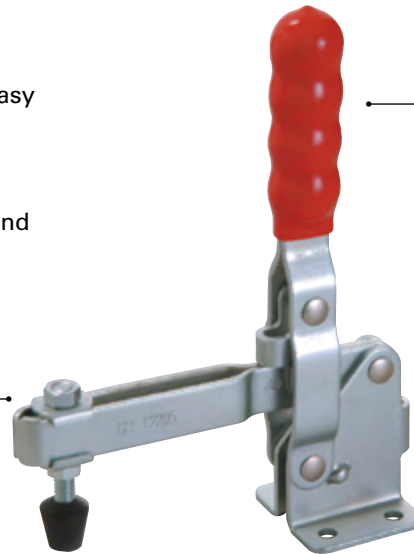

GH-12205

Hand grips are covered with an oil and stain resistant red vinyl or red plastic for easy identification and to assure the safety and comfort of the operator.

TOGGLE ACTION

The theoretical maximum holding of clamping force of a toggle action device is achieved when the three pivot points are in a straight line. To make allowance for external forces due to vibration and changing load conditions in industrial use, the proper amount of over travel of the center pivot point has been carefully calculated to yield maximum clamping pressure,

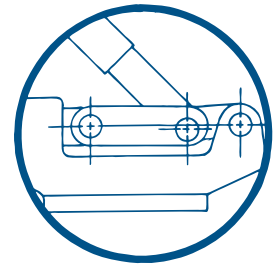

while achieving a positive locking position.

HOLDING CAPACITY AND CLAMPING FORCE

All GOOD HAND™ clamps are rated by their "holding capacity." This rating is the maximum force the clamp will support when locked in the closed position without creating permanent deformation. This force is measured at a point closest to the base and diminishes as the end of the bar is reached. The "clamping force" is defined as the actual force being applied by the clamp to the workpiece. This rating is not constant due to such variables as the location of force on the handle, the amount of force the operator applies, and the location of the spindle on the hold-down bar.

NOTE: Engineering changes, dimensions and specifications referenced in this catalog are subject to change without notice.

Look for this logo throughout our catalog to see our clamps with unique features such as:

- **Higher Base** (Greater clearance)
- **Side Mounting** (Saves fixture space)
- **Yokes** (Clamp 2 parts with 1 stroke)
- **Long U-Bolts** (Extend the reach of Latch Clamps)
- **Reverse Action** (Lowers the profile of Push Pull clamps)

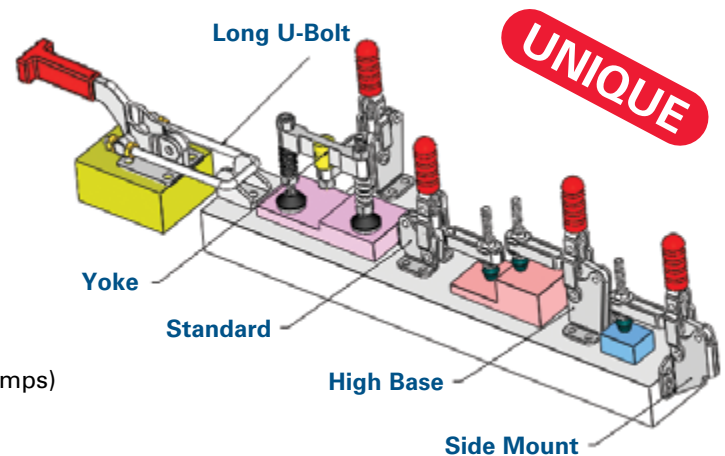



GOOD HAND DE-STA-CO CARR LANE PAGE

Vertical Handle Toggle Clamps

Table with 4 columns: GOOD HAND, DE-STA-CO, CARR LANE, PAGE. Rows include 101-A through 101-JS, 11002-B through 12030, 12044 through 10249, 10250 through 101-JS.

Horizontal Handle Toggle Clamps

Table with 4 columns: GOOD HAND, DE-STA-CO, CARR LANE, PAGE. Rows include 22005 through 22030.

GOOD HAND DE-STA-CO CARR LANE PAGE

Horizontal Handle Toggle Clamps (cont.)

Table with 4 columns: GOOD HAND, DE-STA-CO, CARR LANE, PAGE. Rows include 201 through 204-G.

Push/Pull Toggle Clamps

Table with 4 columns: GOOD HAND, DE-STA-CO, CARR LANE, PAGE. Rows include 301-A through 30607.

GOOD HAND DE-STA-CO CARR LANE PAGE

Push/Pull Toggle Clamps (cont.)

Table with 4 columns: GOOD HAND, DE-STA-CO, CARR LANE, PAGE. Rows include 36010 through 30619.

Latch Type Toggle Clamps

Table with 4 columns: GOOD HAND, DE-STA-CO, CARR LANE, PAGE. Rows include 40323 through 43160.

Toggle Pliers

Table with 4 columns: GOOD HAND, DE-STA-CO, CARR LANE, PAGE. Rows include 50350 through 50450.

GOOD HAND	DE-STA-CO	CARR LANE	PAGE
Cam Type Toggle Clamps			
60130	-	-	38
60131	-	-	38
Heavy Duty Weldable Toggle Clamps			
701-C	-	-	39
701-D	-	-	39
701-K	-	-	39
702-C	-	-	39
702-D	-	-	39
702-K	-	-	39
70305	503-M	-	39
70310	503-MB	-	39
70315	503-MLB	-	39
70505	505-M	-	39
70510	505-MB	-	39
70515	505-MLB	-	39
70605	506-M	-	39
70610	506-MB	-	39
70615	506-MLB	-	39
75027	527	-	40
75027-SM	527-F	-	40
75048	548	-	40
75078	578	-	40
F-Type Clamps			
80325	325	CL-325-PL-S	41
80325-SS	325-SS	-	41
Pneumatic Power Clamps			
10101-A	812	CL-400-PTC	42
12050-A	802-U	CL-500-PTC	42
12130-A	807-U	CL-1001-PTC	42
12132-A	-	CL-1000-PTC	42
12265-A	810-U	-	42
12275-A	810-S	-	42
10247-A	847-U	CL-2000-PTC	42
10249-A	847-S	CL-2001-PTC	42
20820-A	-	-	42
36301-A	816	CL-600-PPC	43
36003-A	803	CL-1500-PPC	43
36330-A	830	-	43
Yoke Assemblies			
YP-3130	-	-	43
YP-3145	-	-	43
YP-3160	-	-	43
YP-3730	-	-	43
YP-3745	-	-	43
YP-3760	-	-	43
Accessories			44
Appendix			45
Strong Hand Tools® Product Lines			46

PICTORIAL INDEX

Vertical Handle Hold Down Action

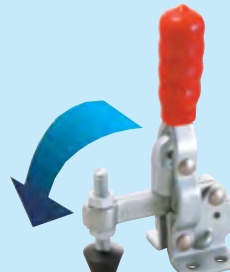

PAGES 1-9

Horizontal Handle Hold Down Action

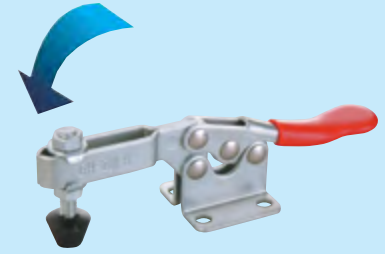

PAGES 10-20

Push/Pull Straight Line Action

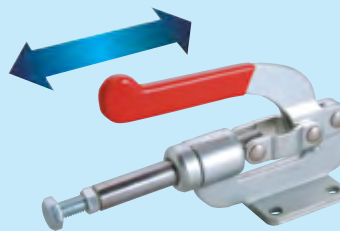

PAGES 21-27

Latch Type Pull Action

** See the new Secure-Lock latch clamps*

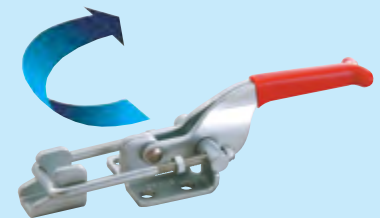

PAGES 28-35

Toggle Pliers Squeeze Action



PAGES 36-37

Cam Type Hold Down Action



PAGES 38

Heavy Duty Weldable Hold Down Action



PAGES 39-40

F-Type Pull Down Action



PAGE 41

Pneumatic Power



PAGES 42-43

Yoke Assemblies



PAGE 43

Accessories	44
Appendix	45
Strong Hand Tools® Product Lines	46

**Product availability subject to change without notice.*

Series 101-A

- Cross Ref. : DE-STA-CO Series 201-U
- Holding Capacity: 110 lbs. (50 kg)
- Weight: 0.13 lb. (60 g)
- Bar opens 100°, Handle 56°
- Spindle Supplied: GH-FC-10138

One of the most affordable clamps. T-handle and straight base options available.

Model	Description
GH-101-A	U-Bar, Flanged Base, Straight Handle
GH-101-ASS	Stainless Steel Model of GH-101-A
GH-101-AI	U-Bar, Straight Base, Straight Handle
GH-101-AIT	U-Bar, Straight Base, T-Handle
GH-101-AT	U-Bar, Flanged Base, T-Handle

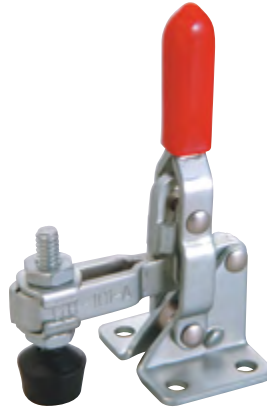

GH-101-A

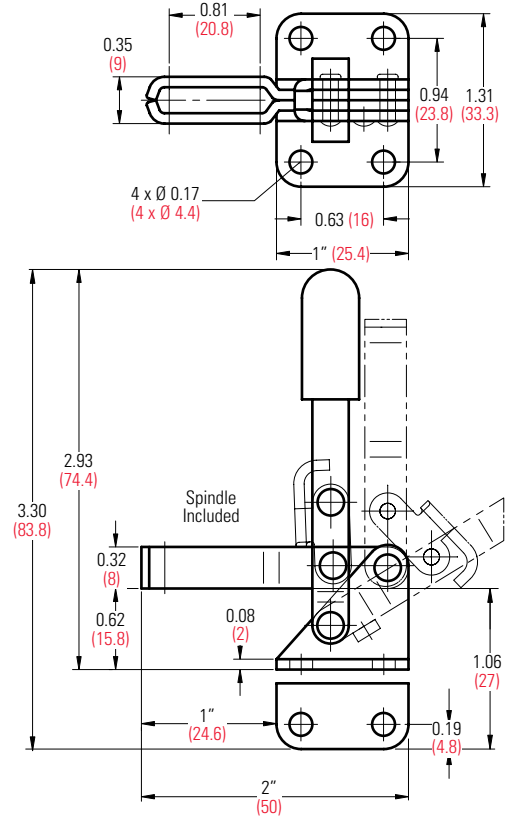

UNIT: inch (metric mm)

Series 11002-B

GH-13002-B has hardened bushings and removable ground pins.

Unique hole pattern for flexibility in a wide range of mounting options.



GH-13002-B

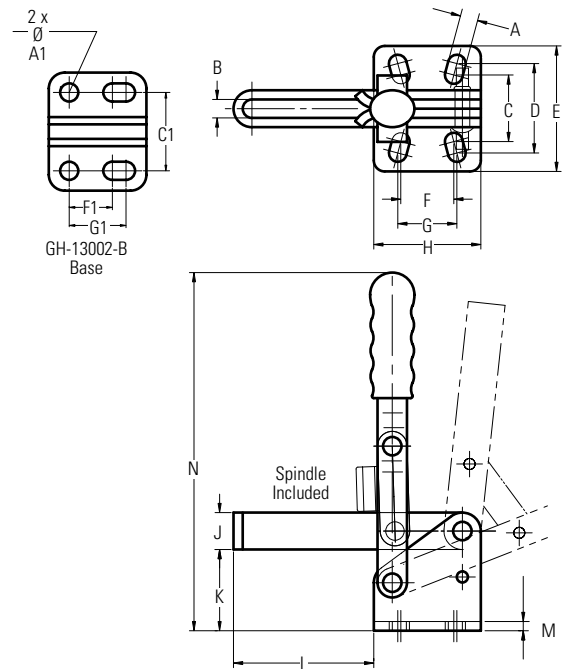

Model	Holding Capacity	Spindle Supplied	Bar Opens	Handle Opens	A	A1	B	C	C1	D	E	F	F1	G	G1	H	J	K	L	M	N	Weight
GH-11002-B	165 lbs. (75 kg)	GH-SA-10118	96°	66°	0.22 (5.6)	-	0.20 (5)	0.70 (18)	-	0.95 (24.2)	1.34 (34)	0.56 (14.3)	-	0.63 (16)	-	1.14 (29)	0.39 (10)	0.87 (22)	1.50 (38)	0.10 (2.5)	3.82 (97)	0.28 lb. (128 g)
GH-12002-B	330 lbs. (150 kg)	GH-SA-14134	108°	70°	0.22 (5.6)	-	0.25 (6.4)	1" (25.4)	-	1.06 (27)	1.65 (42)	0.50 (12.7)	-	0.75 (19)	-	1.38 (35)	0.51 (13)	1.12 (28)	1.73 (44)	0.13 (3.2)	5.63 (143)	0.37 lb. (170 g)
GH-13002-B	550 lbs. (250 kg)	GH-SA-56212	106°	67°	-	0.32 (8)	0.35 (8.8)	-	1.32 (33.5)	-	2.01 (51.1)	-	0.75 (19)	-	1" (25)	1.69 (43)	0.75 (19)	1.38 (35)	3.94 (100)	0.13 (3.2)	7.72 (196)	0.84 lb. (380 g)

UNIT: inch (metric mm)

Series 13005

- Cross Ref. : DE-STA-CO Series 305
- Bar opens 90°, Handle 175°
- GH-13008 has hardened bushings and removable ground pins.

This unique space-saving clamp is very affordable.

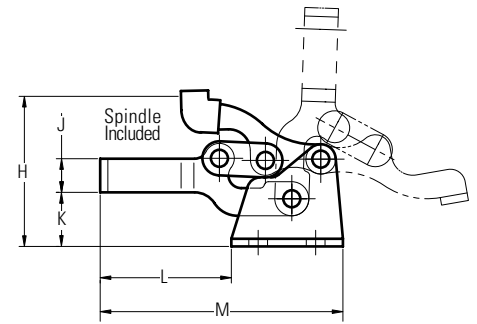
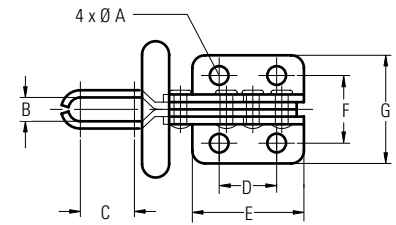

Model	Holding Capacity	Spindle Supplied	Ø A	B	C	D	E	F	G	H	J	K	L	M	Weight
GH-13005	150 lbs. (68 kg)	GH-FC-10138	0.17 (4.4)	0.35 (9)	0.50 (12.7)	0.53 (13.5)	1.03 (26.2)	0.63 (15.9)	1" (25.4)	1.40 (35.2)	0.31 (7.9)	0.50 (12.7)	1.21 (30.8)	2.24 (57)	0.13 lb. (60 g)
GH-13005-SS	Stainless Steel Model of GH-13005														
GH-13007	330 lbs. (150 kg)	GH-FC-56212	0.28 (7)	0.60 (15.2)	0.77 (19.5)	1.06 (27)	1.73 (44)	1.16 (29.4)	1.81 (46)	2.31 (58.7)	0.50 (12.7)	0.87 (22.2)	1.97 (50.1)	3.69 (93.7)	0.50 lb. (230 g)
GH-13008	705 lbs. (320 kg)	GH-FC-38312	0.31 (7.9)	0.75 (19)	1.14 (28.9)	1.54 (39)	2.53 (64.3)	1.50 (38.1)	2.46 (62.7)	3.46 (88.1)	0.75 (19)	1.31 (33.3)	2.66 (67.5)	5.32 (135)	1.38 lbs. (630 g)

UNIT: inch (metric mm)

UNIQUE

13005-HB

High Base Model of GH-13005



GH-13005-HB

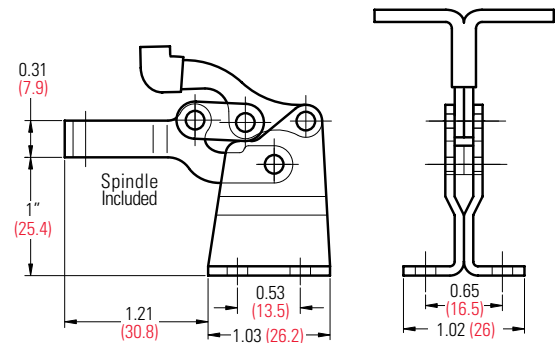

UNIQUE

13005-SM & 13007-SM

Side Mount Model of GH-13005 and GH-13007



GH-13005-SM

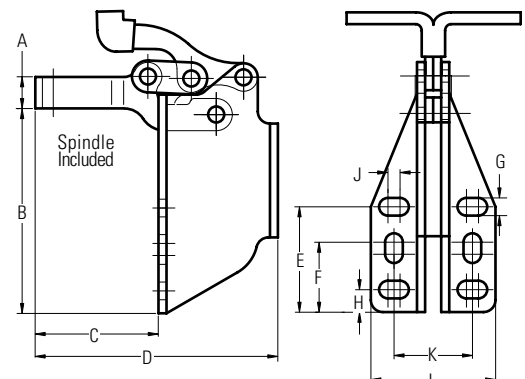

Model	A	B	C	D	E	F	G	H	J	K	L
GH-13005-SM	0.31 (7.9)	2" (50.8)	1.20 (30.6)	2.37 (60.3)	1.03 (26.2)	0.68 (17.4)	0.17 (4.4)	0.22 (5.6)	0.12 (3)	0.76 (19.5)	1.22 (31)
GH-13007-SM	0.50 (12.7)	3.06 (77.8)	1.97 (50.1)	3.80 (96.7)	1.54 (39.2)	1.04 (26.3)	0.28 (7)	0.37 (9.4)	0.16 (4)	1" (25.4)	1.81 (46)

UNIT: inch (metric mm)

Series 12050 *Popular!*

- Cross Ref. : DE-STA-CO Series 202
- Holding Capacity: 200 lbs. (91 kg)
- Weight: 0.38 lb. (170 g)
- Bar opens 100°, Handle 60°
- Spindle Supplied: GH-FC-14134 (GH-SA-14112 for GH-12050-SS)

Model	Description
GH-12050	Fixed Spindle, Flanged Base, Straight Handle
GH-12050-SS	Stainless Steel Model of GH-12050
GH-12050-U	U-Bar, Flanged Base, Straight Handle
GH-12050-UL	Extra Long U-Bar 2.27" (58 mm) Flanged Base, Straight Handle
GH-12055	Fixed Spindle, Straight Base, Straight Handle
GH-12060	Solid Bar, Flanged Base, Straight Handle
GH-12065	Solid Bar, Straight Base, Straight Handle
GH-12070	Fixed Spindle, Flanged Base, T-Handle
GH-12075	Fixed Spindle, Straight Base, T-Handle
GH-12080	Solid Bar, Flanged Base, T-Handle
GH-12085	Solid Bar, Straight Base, T-Handle



GH-12050

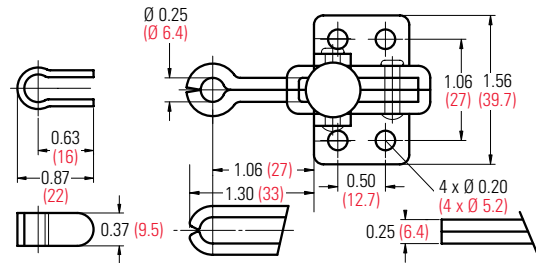

GH-12050-U

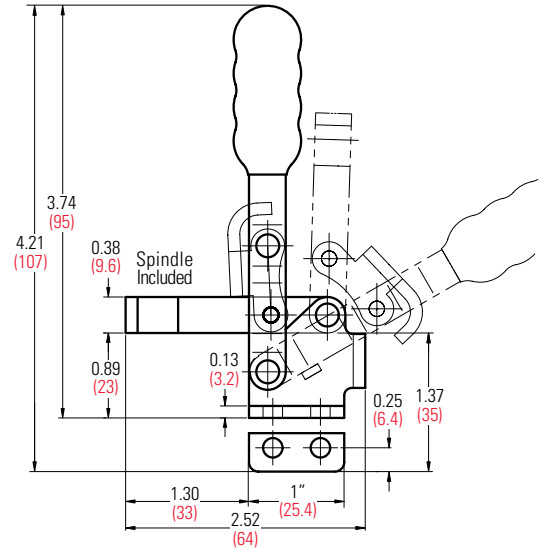

UNIQUE

12050-HB

High Base Model of GH-12050



GH-12050-HB

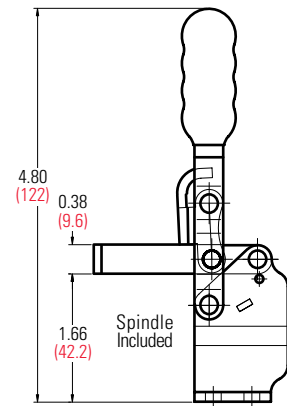

UNIQUE

12050-SM

Side Mount Model of GH-12050



GH-12050-SM

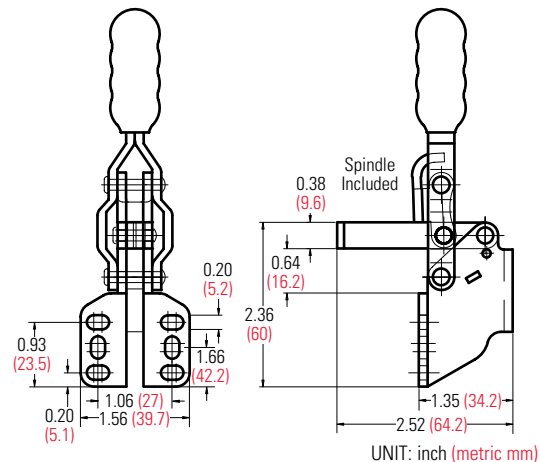

UNIT: inch (metric mm)

101-B

- Holding Capacity: 220 lbs. (100 kg)
- Weight: 0.3 lb. (135 g)
- Bar opens 90°, Handle 65°
- Spindle Supplied: GH-FC-14134

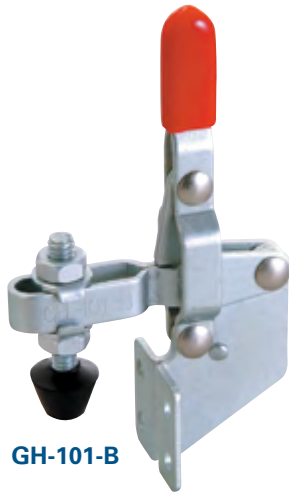

GH-101-B

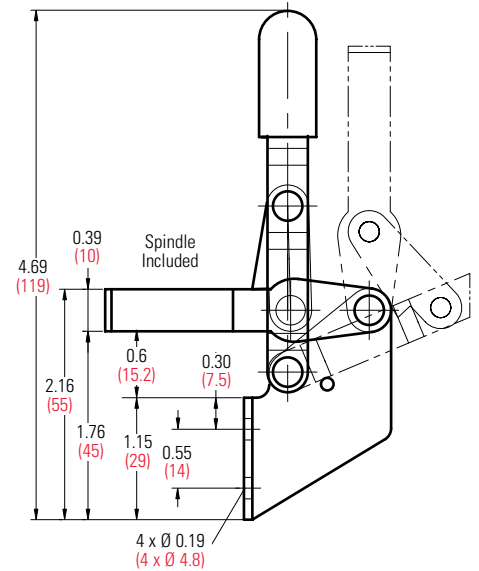
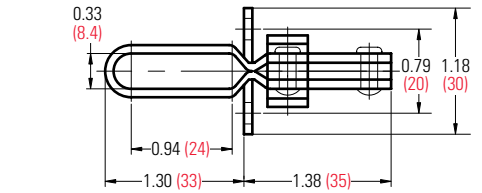

UNIT: inch (metric mm)

102-B

- Holding Capacity: 220 lbs. (100 kg)
- Weight: 0.25 lb. (115 g)
- Bar opens 90°, Handle 65°
- Spindle Supplied: GH-FC-14134

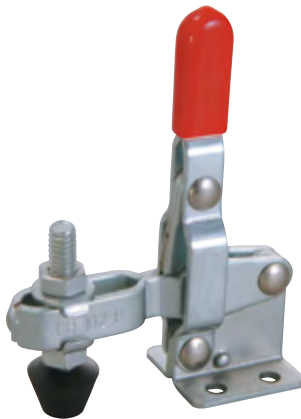

GH-102-B

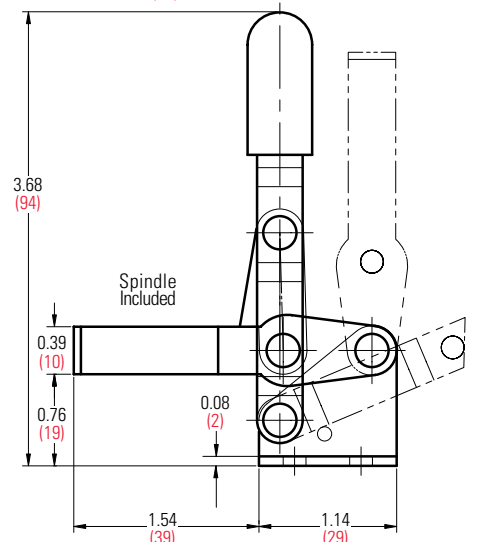
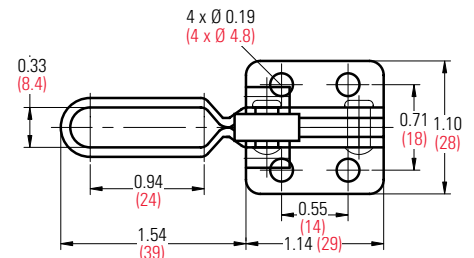

UNIT: inch (metric mm)

106-B

- Holding Capacity: 220 lbs. (100 kg)
- Weight: 0.4 lb. (184 g)
- Bar opens 82°, Handle 55°
- Spindle Supplied: GH-FC-14134



GH-106-B

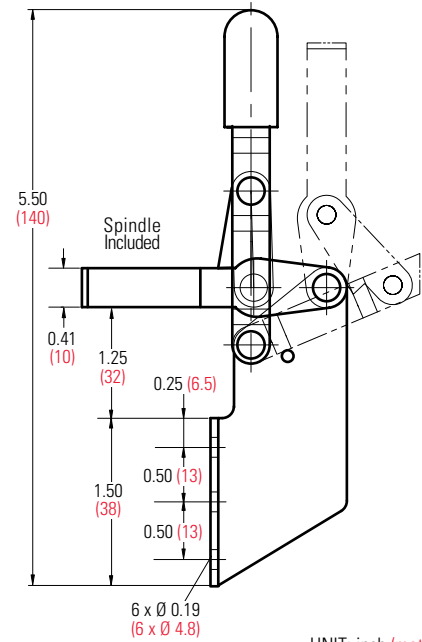
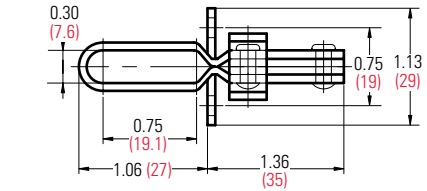

UNIT: inch (metric mm)

12205

- Holding Capacity: 400 lbs. (182 kg)
- Weight: 1.36 lbs. (620 g)
- Bar opens 100°, Handle 57°
- Spindle Supplied: GH-FC-56212

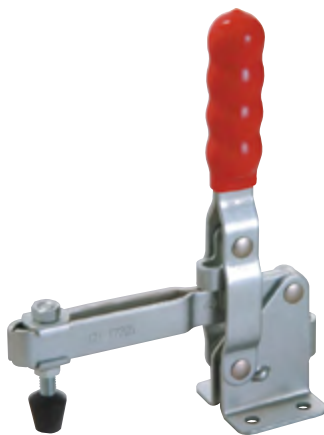

GH-12205

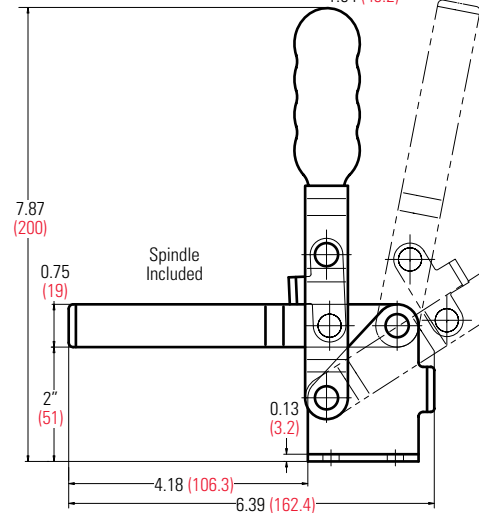
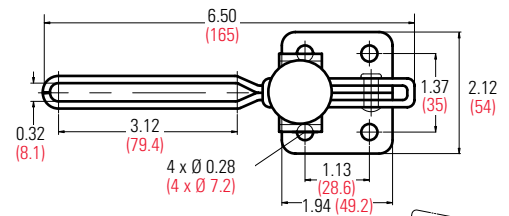

UNIT: inch (metric mm)

Series 12130

Popular!

- Cross Ref. : DE-STA-CO Series 207
- Holding Capacity: 500 lbs. (227 kg)
- Bar opens 100°, Handle 60°
- Spindle Supplied: GH-FC-56212

Expanded Selection. This is the most popular vertical handle toggle clamps. Many options are available.

Model	Description	Weight
GH-12130	Short U-Bar, Flanged Base, Straight Handle	0.78 lb. (355 g)
GH-12130-SS	Stainless Steel Model of GH-12130	
GH-12131	Short U-bar, Flanged Base, T-Handle	0.81 lb. (370 g)
GH-12132	Long U-Bar, Flanged Base, Straight Handle	0.81 lb. (370 g)
GH-12133	Long U-Bar, Flanged Base, T-Handle	0.88 lb. (400 g)
GH-12135	Short U-Bar, Straight Base, Straight Handle	0.78 lb. (355 g)
GH-12136	Short U-Bar, Straight Base, T-Handle	0.81 lb. (370 g)
GH-12137	Long U-Bar, Straight Base, Straight Handle	0.81 lb. (370 g)
GH-12138	Long U-Bar, Straight Base, T-Handle	0.88 lb. (400 g)
GH-12140	Short Solid Bar, Flanged Base, Straight Handle	0.75 lb. (340 g)
GH-12141	Short Solid Bar, Flanged Base, T-Handle	0.78 lb. (355 g)
GH-12142	Long Solid Bar, Flanged Base, Straight Handle	0.78 lb. (355 g)
GH-12143	Long Solid Bar, Flanged Base, T-Handle	0.81 lb. (375 g)
GH-12145	Short Solid Bar, Straight Base, Straight Handle	0.75 lb. (340 g)
GH-12146	Short Solid Bar, Straight Base, T-Handle	0.78 lb. (355 g)
GH-12147	Long Solid Bar, Straight Base, Straight Handle	0.78 lb. (355 g)
GH-12148	Long Solid Bar, Straight Base, T-Handle	0.81 lb. (375 g)

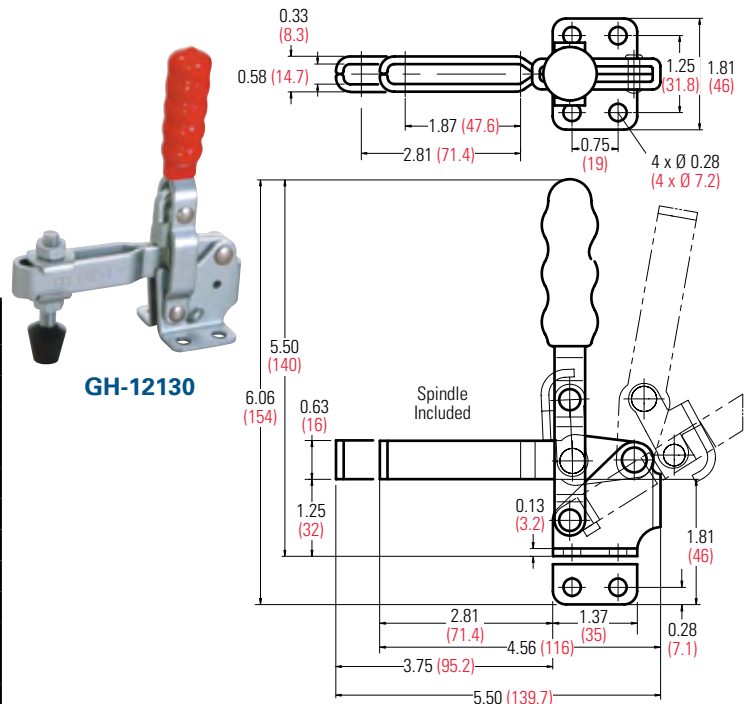

UNIQUE

12130-HB

High Base Model of GH-12130



GH-12130-HB

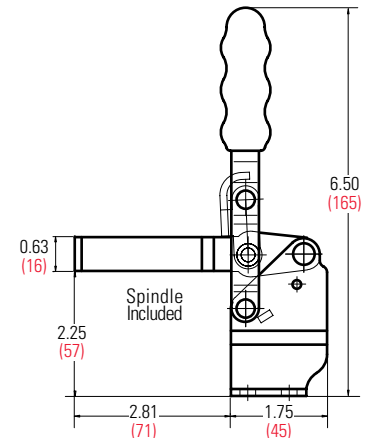

UNIQUE

12130-SM

Side Mount Model of GH-12130



GH-12130-SM

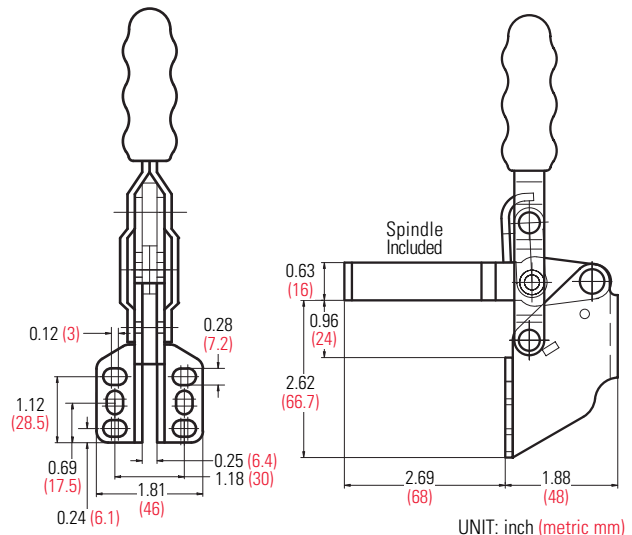

UNIT: inch (metric mm)

Series 12265 *Popular!*

- Cross Ref. : DE-STA-CO Series 210-U(SS)
- Holding Capacity: 750 lbs. (340 kg)
- Bar opens 105°, Handle 58°
- Spindle Supplied: GH-FC-38312 (GH-SA-38300 for GH-12265-SS)
- Hardened bushings and removable ground pins



GH-12265

Model	Description	Weight
GH-12265	U-Bar, Flanged Base, Straight Handle	1.40 lbs. (635 g)
GH-12265-SS	Stainless Steel Model of GH-12265	
GH-12270	U-Bar, Straight Base, Straight Handle	1.40 lbs. (635 g)
GH-12275	Solid Bar, Flanged Base, Straight Handle	1.50 lbs. (680 g)
GH-12280	Solid Bar, Straight Base, Straight Handle	1.50 lbs. (680 g)
GH-12285	U-Bar, Flanged Base, T-Handle	1.57 lbs. (710 g)
GH-12290	U-Bar, Straight Base, T-Handle	1.57 lbs. (710 g)
GH-12295	Solid Bar, Flanged Base, T-Handle	1.62 lbs. (735 g)
GH-12300	Solid Bar, Straight Base, T-Handle	1.62 lbs. (735 g)

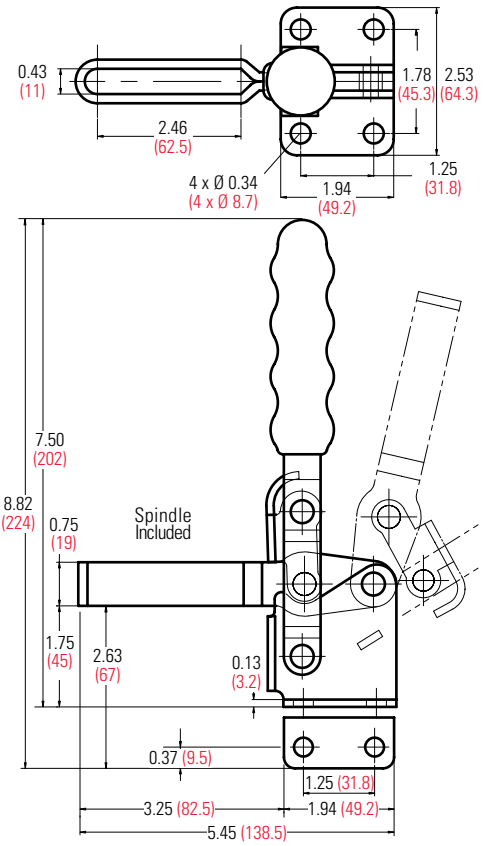

UNIT: inch (metric mm)

Series 12305

- Holding Capacity: 750 lbs. (364 kg)
- Weight: 2.18 lbs. (990 g)
- Bar opens 100°, Handle 65°
- Spindle Supplied: GH-FC-38312

Note the angular spindle bar. Available with open or solid spindle bars. Solid bar can be shortened, and the supplied bolt retainer welded on. Angular bar keeps the overall height low, yet bar clearance high.



GH-12305

Model	Description
GH-12305	Open bar, Flanged Base
GH-12310	Open Bar, Straight Base
GH-12315	Solid Bar, Flanged Base
GH-12320	Solid Bar, Straight Base

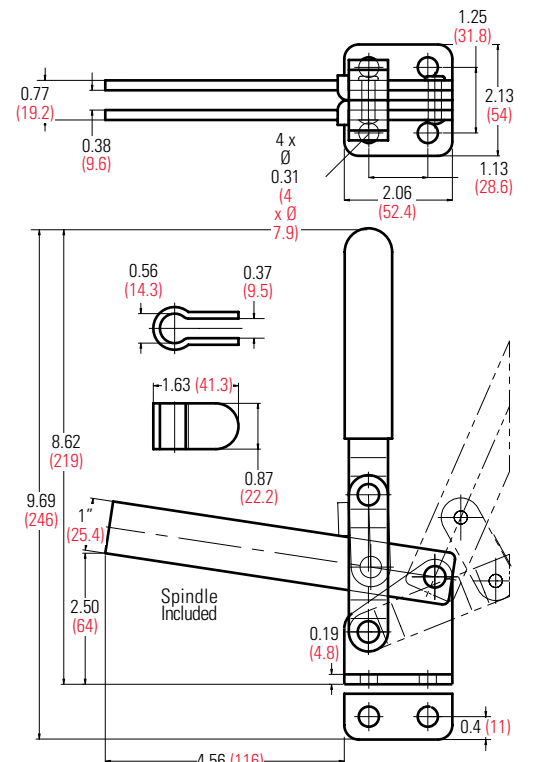

UNIT: inch (metric mm)

Series 10444 *Welder's Choice!*

- Holding Capacity: 880 lbs. (400 kg)
- Bar opens: 85°, Handle 58°
- Spindle Supplied: GH-SA-38300 (GH-SA-38200 for GH-10448)
- **Hardened bushings and removable ground pins**

This rugged yet smooth functioning clamp is designed for use in ovens. It has a rounded handle with no plastic cover.



GH-10448

Model	Description	Weight
GH-10444	Long Bar	1.92 lbs. (870 g)
GH-10448	Short Bar	1.85 lbs. (840 g)

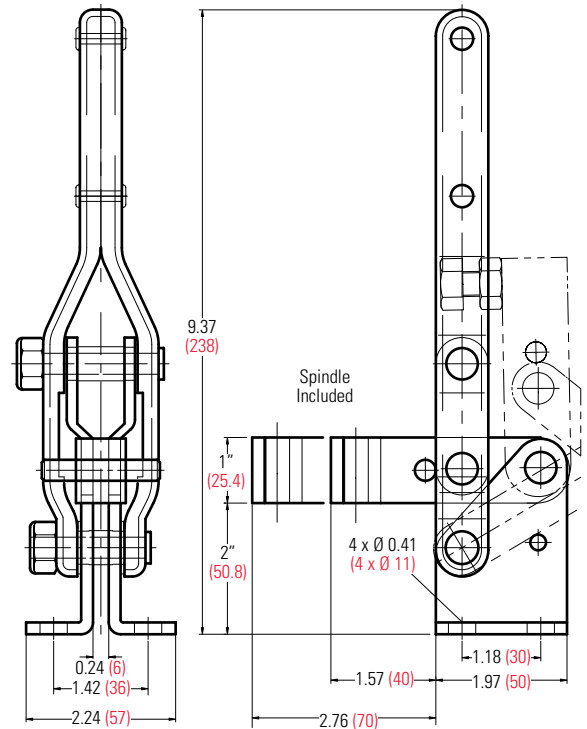

UNIT: inch (metric mm)

Series 10247

- Cross Ref. : DE-STA-CO Series 247
- Holding Capacity: 1,000 lbs. (450 kg)
- Weight: 2.76 lbs. (1,250 g)
- Bar opens 100°, Handle 58° (with roll pin)
- Bar opens 135°, Handle 70° (without roll pin)
- Spindle Supplied: GH-SA-12300
- Hardened bushings and removable ground pins

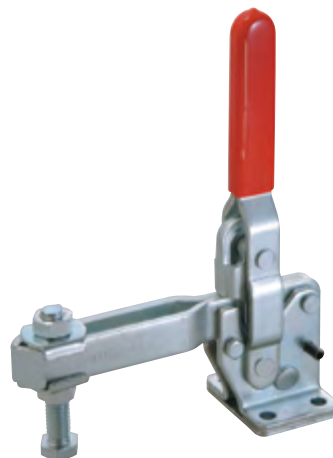

GH-10247

Model	Description
GH-10247	U-Bar, Flanged Base
GH-10248	U-Bar, Straight Base
GH-10249	Solid Bar, Flanged Base
GH-10250	Solid Bar, Straight Base

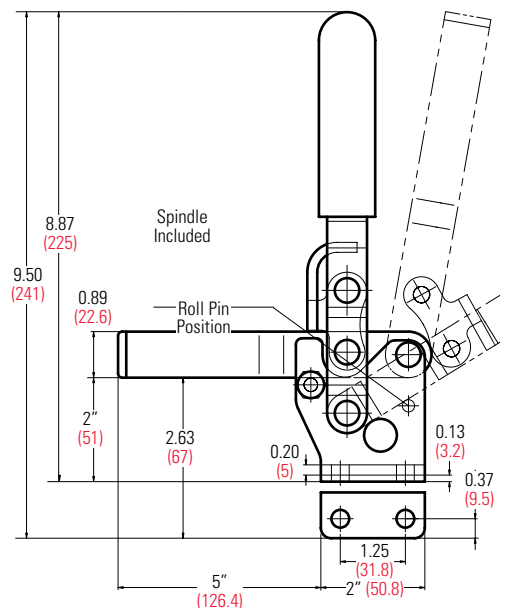
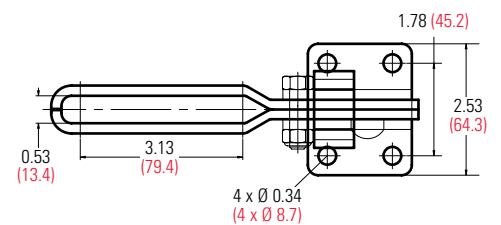

UNIT: inch (metric mm)

Series 101-J

- Cross Ref. : DE-STA-CO Series 267
- Holding Capacity: 1,200 lbs. (550 kg)
- Weight: 5.6 lbs. (2,540 g)
- Bar opens 100°, Handle 48° (with roll pin on top)
- Bar opens 140°, Handle 60° (with roll pin on bottom)
- Spindle Supplied: GH-SA-58500
- **Hardened bushings and removable ground pins**

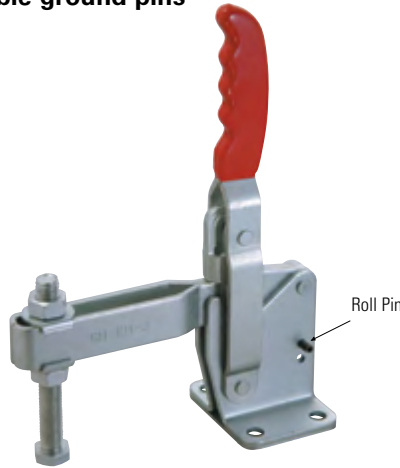

GH-101-J

Model	Description
GH-101-J	U-Bar, Flanged Base
GH-101-JS	Solid Bar, Flanged Base

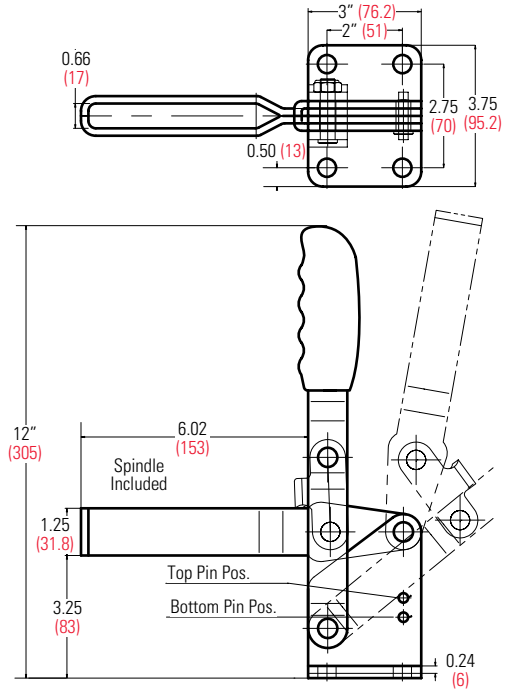

UNIT: inch (metric mm)

Series 22005

- Holding Capacity: 50 lbs. (22.7 kg)
- Weight: 0.06 lb. (25 g)
- Bar opens: 90°, Handle 60°
- Spindle Supplied: GH-SA-08034 (Nylon)



GH-22025

Model	Description
GH-22005	High Bar, Flanged Base
GH-22010	High Bar, Straight Base
GH-22025	Low Bar, Flanged Base
GH-22030	Low Bar, Straight Base

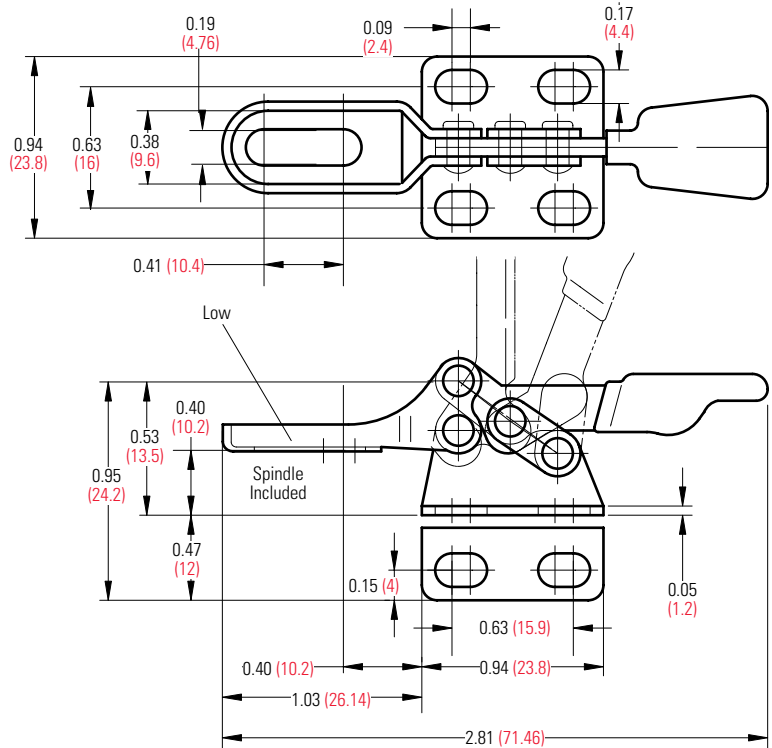

UNIT: inch (metric mm)

Series 201

- Cross Ref.: DE-STA-CO Series 205
- Holding Capacity: 60 lbs. (27 kg)
- Weight: 0.09 lb. (40 g)
- Bar opens: 90°, Handle 80°
- Spindle Supplied: GH-SA-08034 (Nylon)

This compact clamp is the most economical horizontal toggle clamp. Most suitable for holding down sheet metal or circuit boards. Many spindle bar and base combinations available.



GH-201



GH-201-A

Model	Description
GH-201	U-Bar, Flanged Base
GH-201-SS	Stainless Steel Model of GH-201
GH-201-I	U-Bar, Straight Base
GH-201-L	U-Bar, Left Hand Flanged Base
GH-201-R	U-Bar, Right Hand Flanged Base
GH-201-A	Fixed Bar, Flanged Base
GH-201-ASS	Stainless Steel Model of GH-201-A
GH-201-AI	Fixed Bar, Straight Base
GH-201-AL	Fixed Bar, Left Hand Flanged Base
GH-201-AR	Fixed Bar, Right Hand Flanged Base

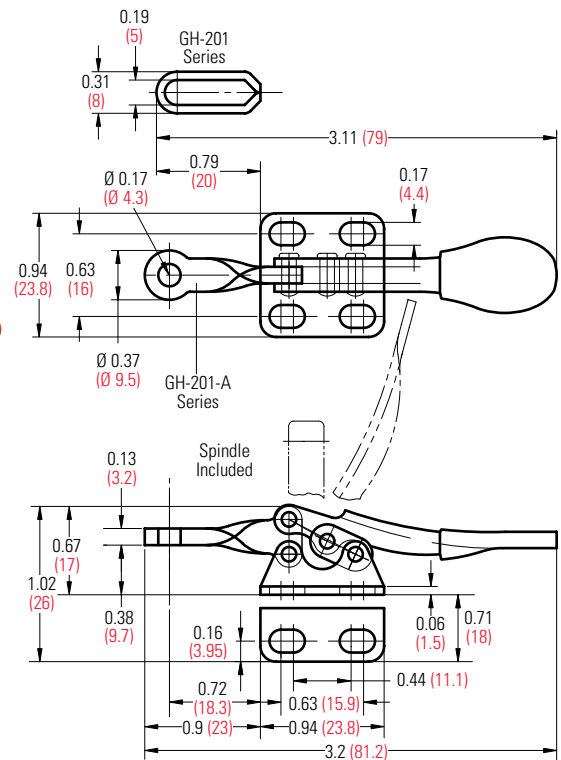

UNIT: inch (metric mm)

20800 & 20800-SS

- Holding Capacity: 66 lbs. (30 kg)
- Weight: 0.09 lb. (40 g)
- Bar opens: 80°, Handle 88°
- Spindle Supplied

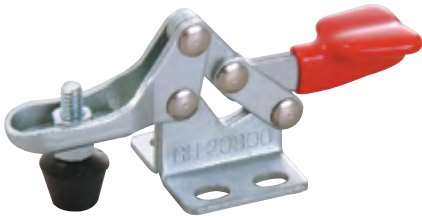

GH-20800

Model	Description
GH-20800	Flanged Base
GH-20800-SS	Stainless Steel Model of GH-20800

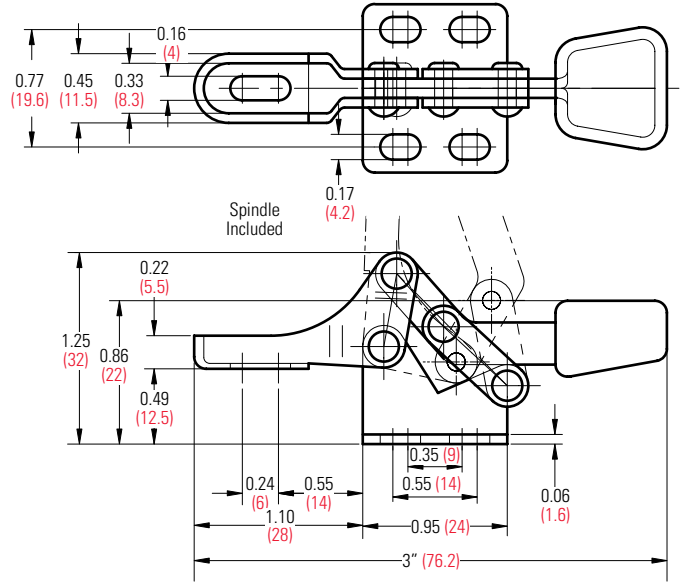

UNIT: inch (metric mm)

20300

- Holding Capacity: 66 lbs. (30 kg)
- Weight: 0.22 lb. (100 g)
- Bar opens: 65°, Handle 55°
- Spindle Supplied

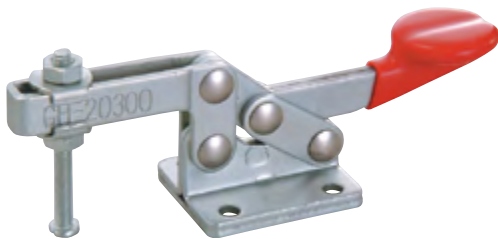

GH-20300

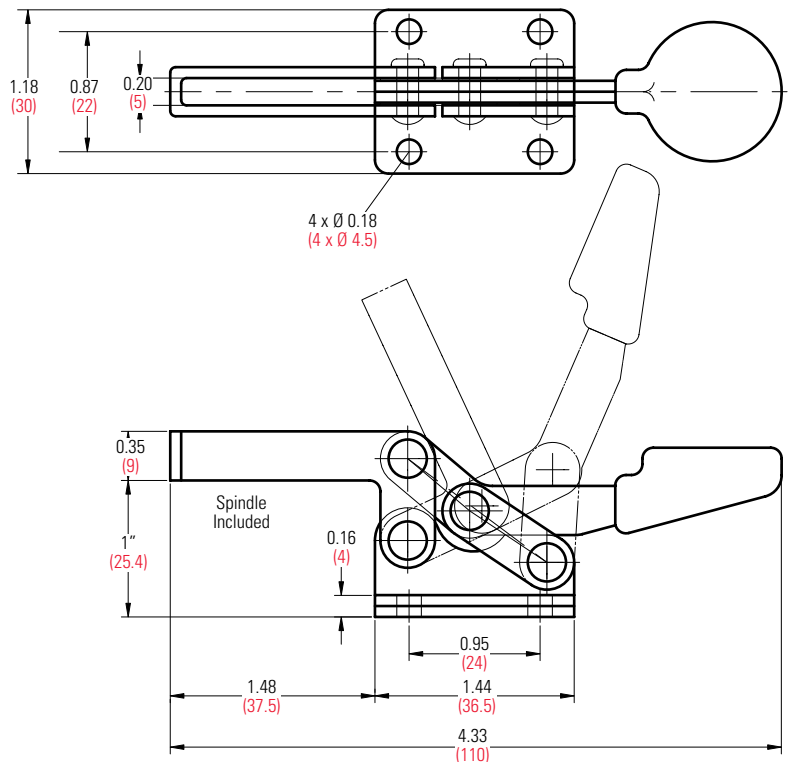

UNIT: inch (metric mm)

22100 & 22105

- Holding Capacity: 150 lbs. (68 kg)
- Weight: 0.24 lb. (110 g)
- Bar opens: 90°, Handle 90°
- Spindle Supplied: GH-FC-14134

Almost identical to the 201-B model (pg. 13). Lighter and more affordable.



GH-22100

Model	Description
GH-22100	Flanged Base
GH-22105	Straight Base

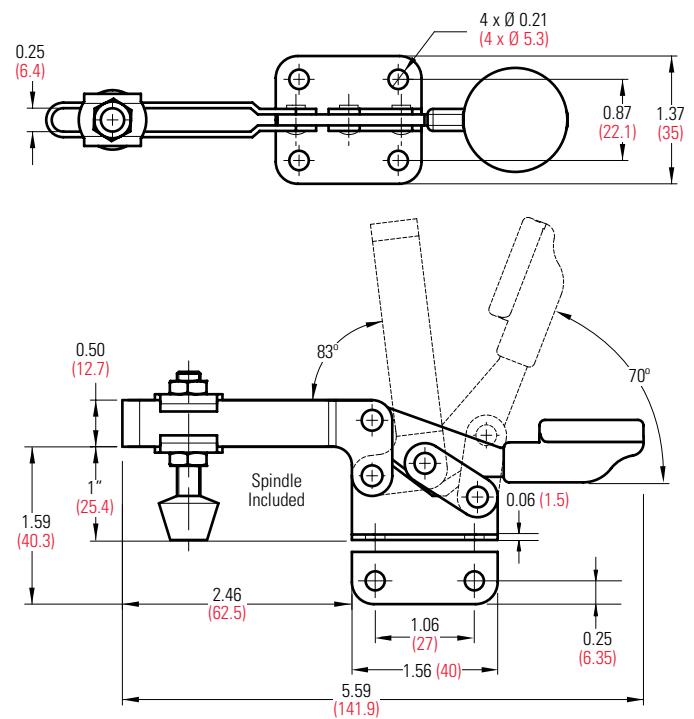

UNIT: inch (metric mm)

Series 20752-B

- Bar opens: 94°, Handle 76°
- Spindle Supplied.

The "hunch back" design leaves extra room for your fingers. All models have the red ribbed handles and come with hex bolt spindles.

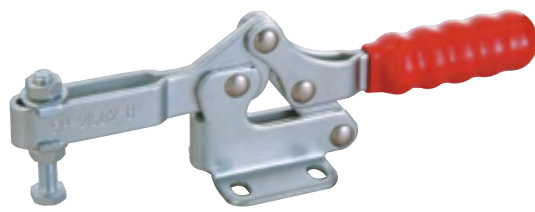

GH-21502-B

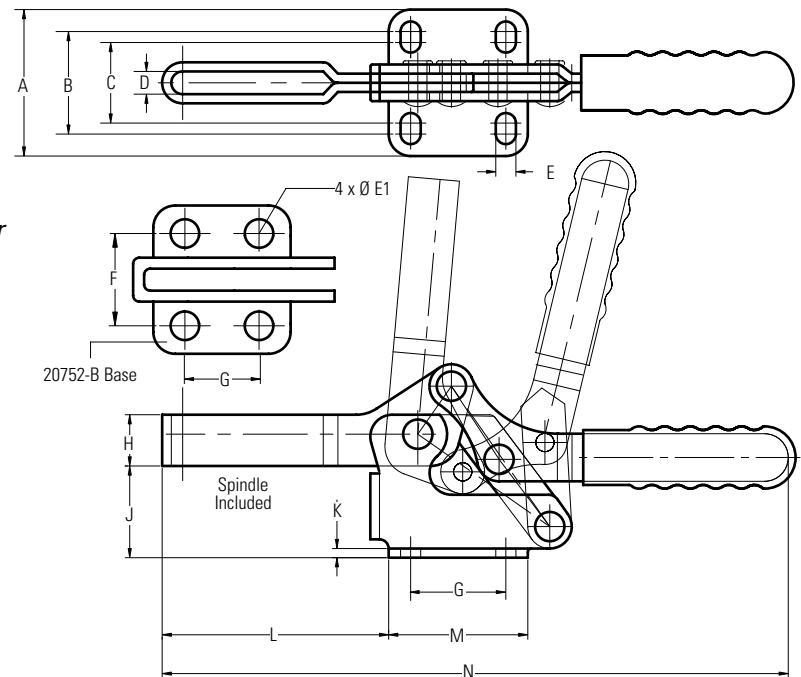

Model	Holding Capacity	A	B	C	D	E	Ø E1	F	G	H	J	K	L	M	N	Weight
GH-20752-B	165 lbs. (75 kg)	1.06 (27)	-	-	0.21 (5.3)	-	0.20 (5.2)	0.66 (16.8)	0.53 (13.5)	0.37 (9.5)	0.75 (19)	0.08 (2)	1.41 (36)	1" (25)	4.11 (104)	0.22 lb. (100 g)
GH-21502-B	330 lbs. (150 kg)	1.57 (40)	1.10 (28)	0.87 (22)	0.24 (6.2)	0.22 (5.5)	-	-	1.02 (26)	0.55 (14)	1" (25.1)	0.10 (2.5)	2.44 (62)	1.50 (38)	6.73 (171)	0.50 lb. (230 g)
GH-22502-B	550 lbs. (250 kg)	1.85 (47)	1.22 (31)	1.02 (26)	0.35 (9)	0.26 (6.6)	-	-	1.02 (26)	0.69 (17.5)	1.34 (34)	0.12 (3)	3.11 (79)	1.65 (42)	8.62 (219)	0.95 lb. (430 g)

UNIT: inch (metric mm)

Series 201-B *Popular!*

- Cross Ref.: DE-STA-CO Series 215
- Holding Capacity: 200 lbs. (90 kg)
- Weight: 0.29 lb. (130 g)
- Bar opens: 85°, Handle 60°
- Spindle Supplied: GH-FC-14134

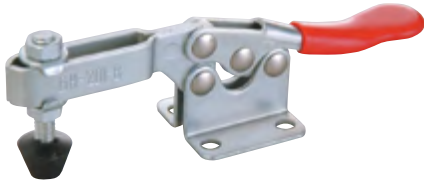

GH-201-B

Model	Description	A	Ø B	C
GH-201-B	U-Bar, Flanged Base	0.29 (7.4)	-	-
GH-201-BSS	Stainless Steel Model of GH-201-B	0.29 (7.4)	-	-
GH-201-BI	U-Bar, Straight Base	0.29 (7.4)	-	-
GH-201-BS	Solid Bar, Flanged Base	-	0.28 (7.1)	0.16 (4)
GH-201-BSI	Solid Bar, Straight Base	-	0.28 (7.1)	0.16 (4)

UNIT: inch (metric mm)

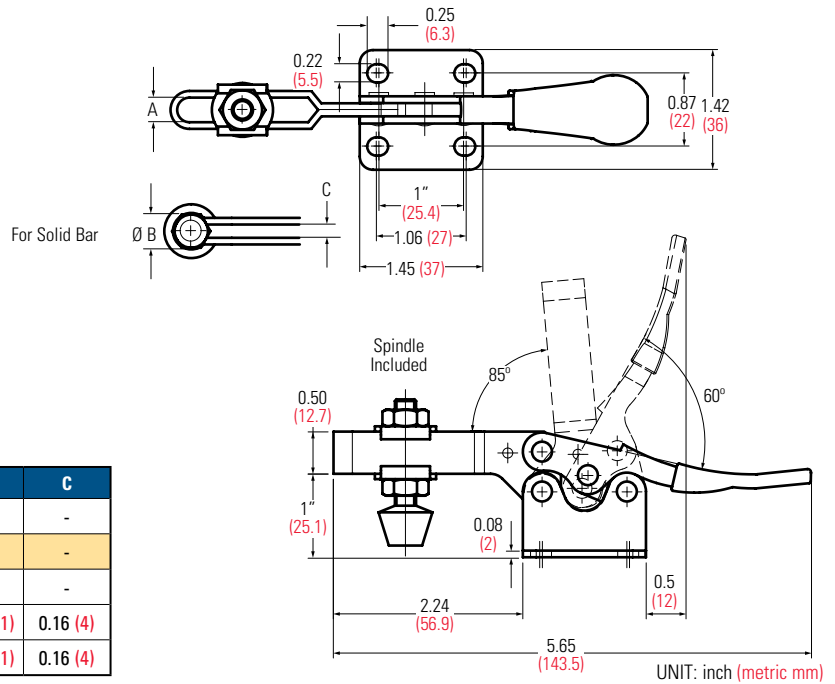

UNIQUE

201-BHB

- High Base Model of GH-201-B
- Weight: 0.32 lb. (146 g)



GH-201-BHB

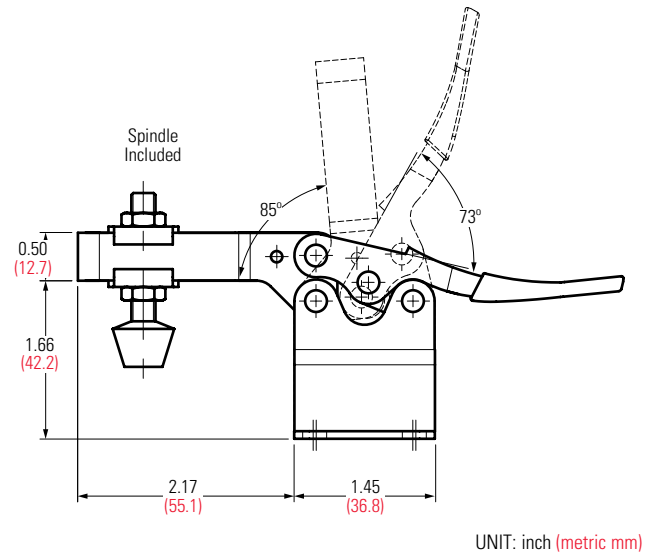

UNIQUE

201-BSM

- Side Mount Model of GH-201-B
- Weight: 0.36 lb. (163 g)



GH-201-BSM

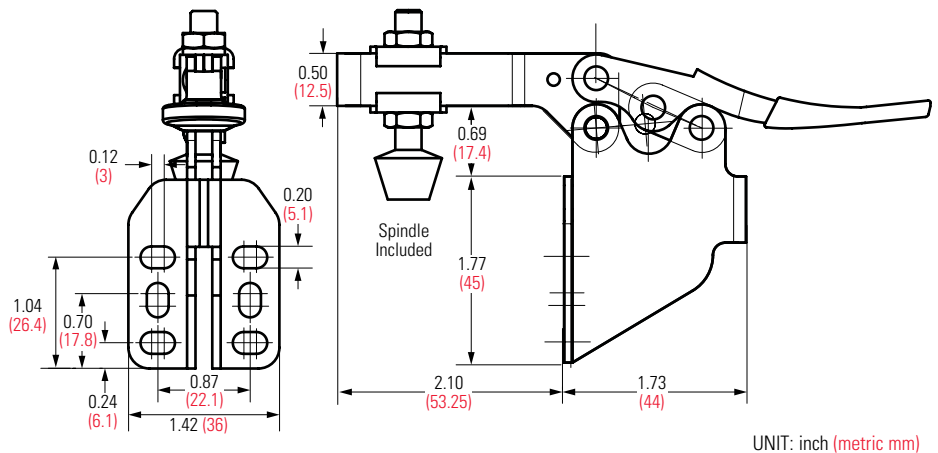

UNIT: inch (metric mm)

20820

- Cross Ref.: DE-STA-CO Model 317-U
- Holding Capacity: 220 lbs. (100 kg)
- Weight: 0.88 lb. (400 g)
- Bar opens: 185°, Handle 60°
- Spindle Supplied: GH-FC-56212

Mount vertically and horizontally



GH-20820

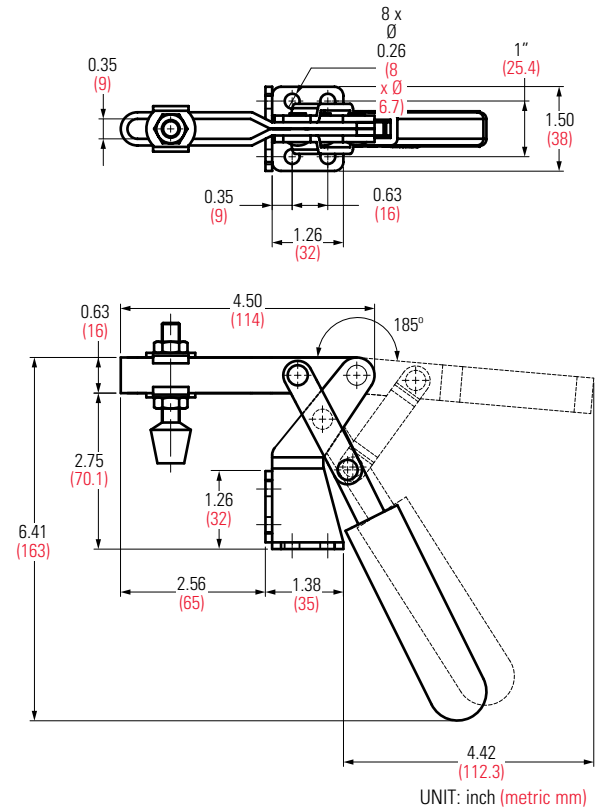

Series 203-F & 202-F

- Holding Capacity: 500 lbs. (227 kg)
- Bar opens: 85°, Handle 58°
- Spindle Supplied: GH-FC-56212

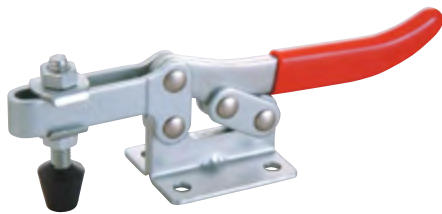

GH-203-F

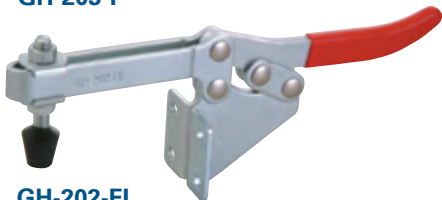

GH-202-FL

Model	Description	A	Weight
GH-203-F	U-Bar, Flanged Base	2.24 (57)	0.75 lb. (340 g)
GH-203-FL	Long U-Bar, Flanged Base	3.70 (94)	0.84 lb. (380 g)
GH-202-F	U-Bar, Side Mounted	2.05 (52)	0.85 lb. (385 g)
GH-202-FL	Long U-Bar, Side Mounted	3.50 (89)	0.94 lb. (425 g)

UNIT: inch (metric mm)

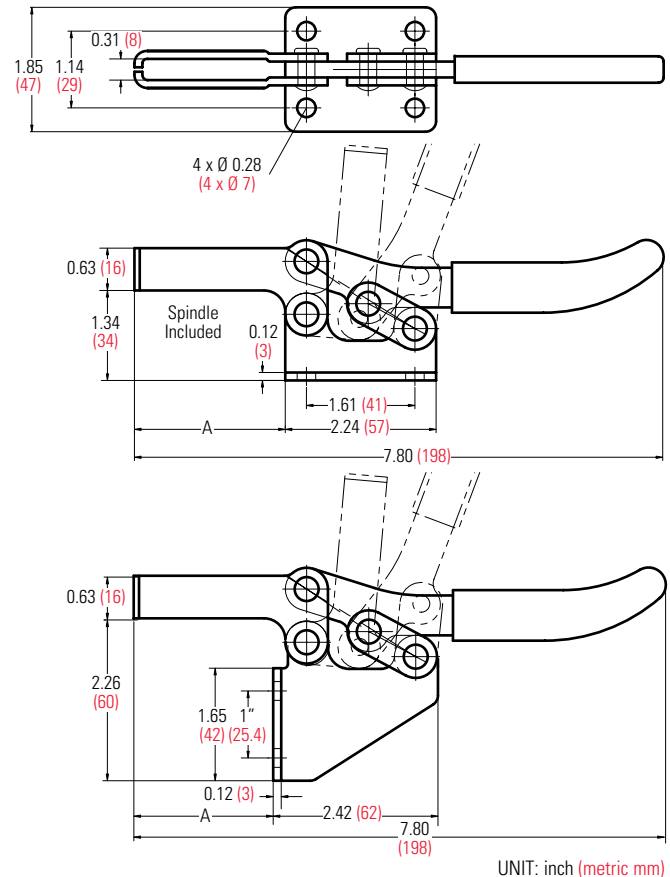

UNIT: inch (metric mm)

Series 225-D *Popular!*

- Cross Ref.: DE-STA-CO Series 225
- Holding Capacity: 500 lbs. (227 kg)
- Weight: 0.59 lb. (265 g)
- Bar opens: 90°, Handle 65°
- Spindle Supplied: GH-FC-56212

This is the most popular horizontal handle toggle clamp. See Series GH-22165 for extra long U-Bars.



GH-225-D

Model	Description
GH-225-D	U-Bar, Flanged Base
GH-225-DSS	Stainless Steel Model of GH-225-D
GH-225-DI	U-Bar, Straight Base

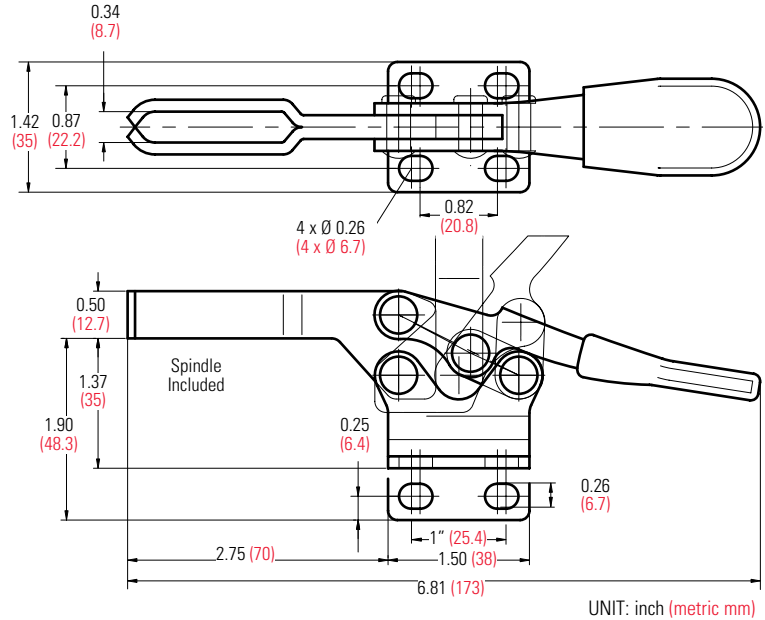

UNIQUE

225-DHB

- **High Base Model** of GH-225-D
- Weight: 0.63 lb. (286 g)



GH-225-DHB

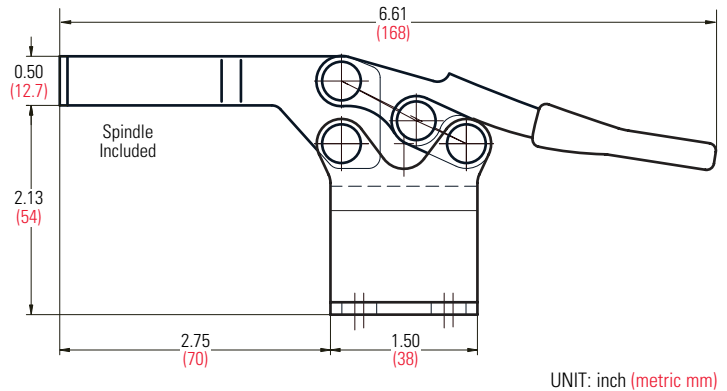

UNIQUE

225-DSM

- **Side Mount Model** of GH-225-D
- Weight: 0.69 lb. (315 g)



GH-225-DSM

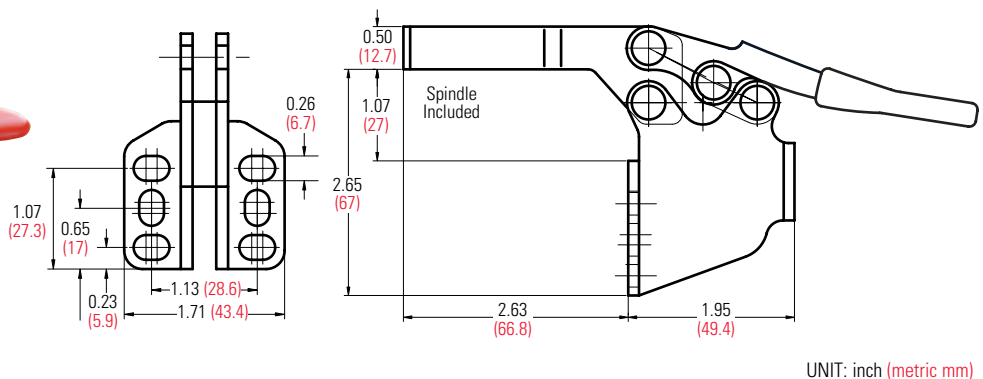

Series 22165

- Holding Capacity: 550 lbs. (250 kg)
- Bar opens: 96°, Handle 88°
- Spindle Supplied: GH-FC-56212

Expanded selection. Larger version of Series 225-D



GH-22165

Model	Description	A	B	C	D	Weight
GH-22165	Short U-Bar, Flanged Base	1.31 (33.3)	2.81 (71.4)	1.81 (46)	7.28 (185)	0.63 lb. (285 g)
GH-22170	Short U-Bar, Straight Base		2.99 (76)			
GH-22175	Short Solid Bar, Flanged Base	1.13 (28.6)	6.50 (165)	1.63 (41)	10.99 (279.2)	0.78 lb. (360 g)
GH-22180	Short Solid Bar, Straight Base		6.56 (167)			
GH-22185	Long U-Bar, Flanged Base	1.13 (28.6)	6.50 (165)	1.63 (41)	10.99 (279.2)	0.78 lb. (360 g)
GH-22190	Long U-Bar, Straight Base		6.56 (167)			
GH-22195	Long Solid Bar, Flanged Base	1.13 (28.6)	6.50 (165)	1.63 (41)	10.99 (279.2)	0.78 lb. (360 g)
GH-22200	Long Solid Bar, Straight Base		6.56 (167)			

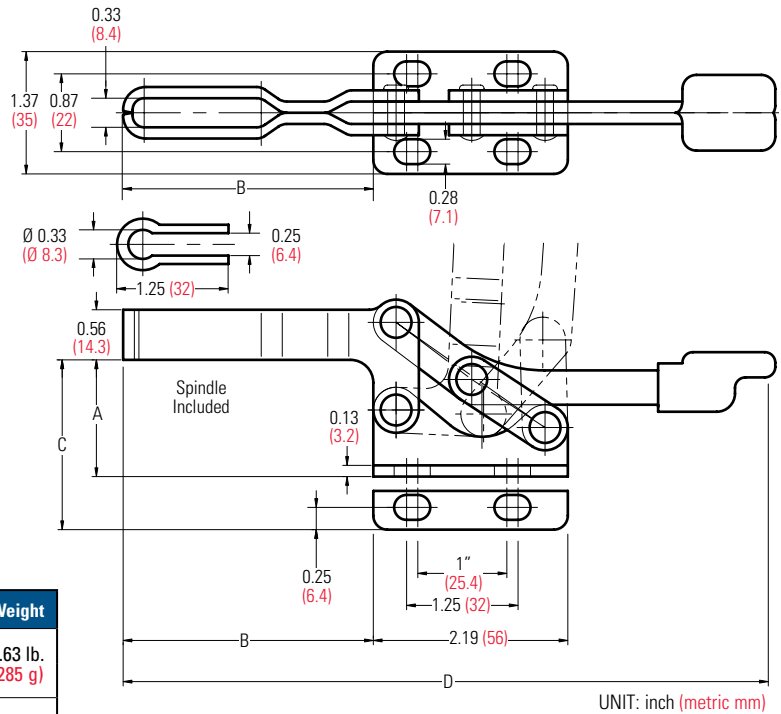

21383

- Holding Capacity: 550 lbs. (250 kg)
- Weight: 0.46 lb. (209 g)
- Bar opens: 72°, Handle 72°
- Spindle Supplied: GH-SA-56212

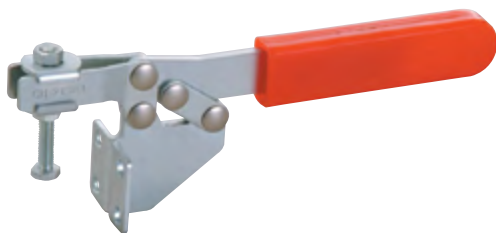

GH-21383

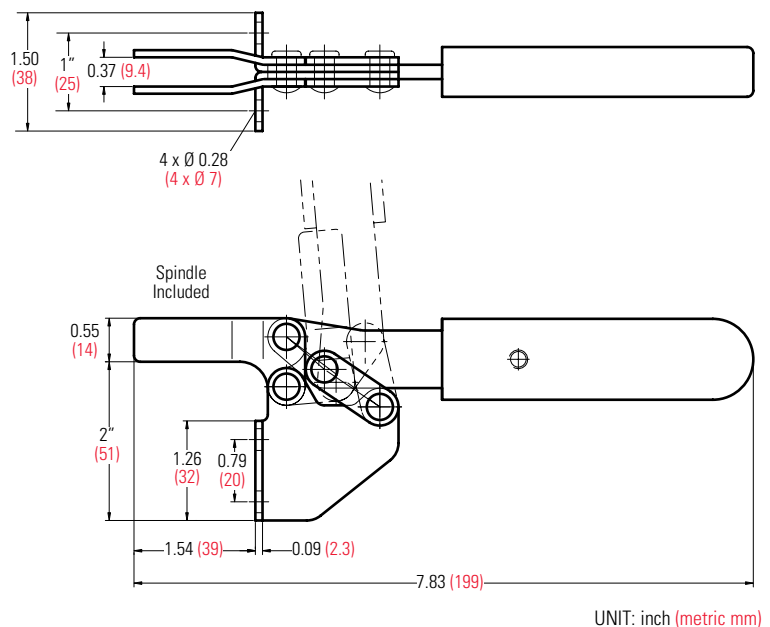

25383

- Holding Capacity: 600 lbs. (280 kg)
- Weight: 0.96 lb. (435 g)
- Bar opens: 80°, Handle 80°
- Spindle Supplied

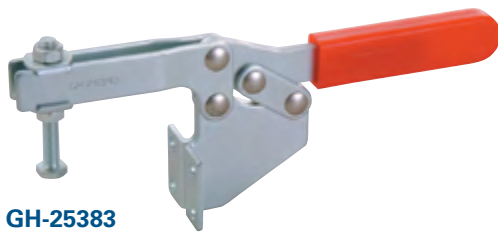

GH-25383

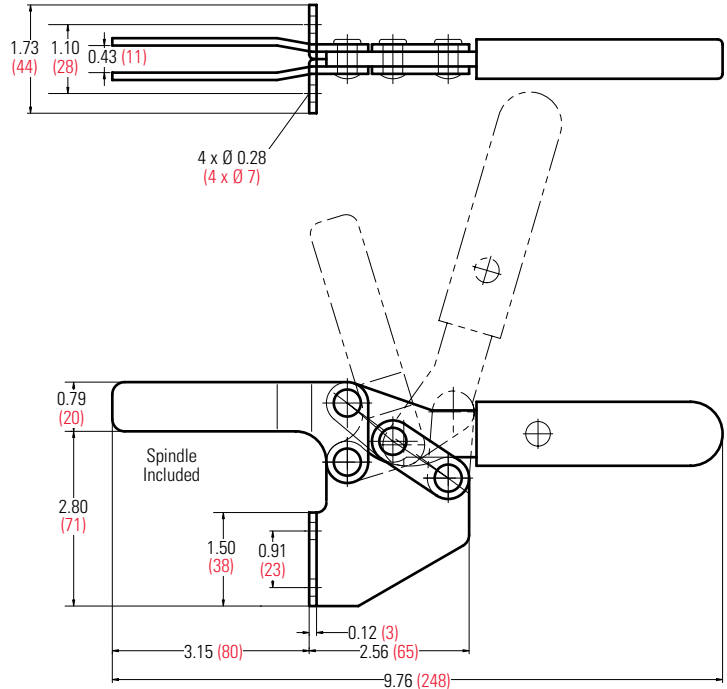

UNIT: inch (metric mm)

22235

- Holding Capacity: 600 lbs. (273 kg)
- Weight: 1.41 lbs. (640 g)
- Bar opens: 111°, Handle 94°
- Spindle Supplied: GH-FC-56212



GH-22235

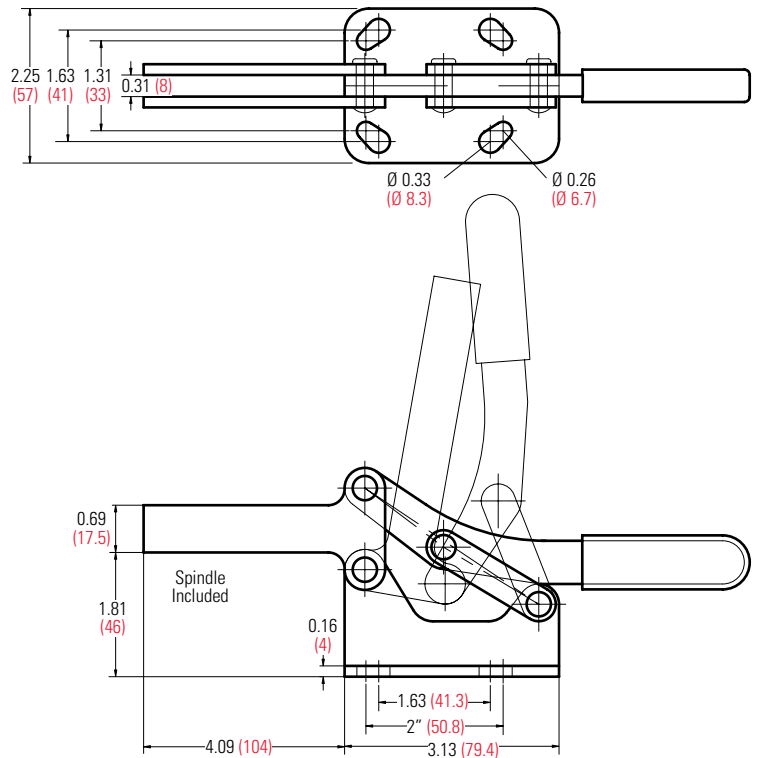

UNIT: inch (metric mm)

25382

- Holding Capacity: 620 lbs. (280 kg)
- Weight: 0.84 lb. (380 g)
- Bar opens: 80°, Handle 80°
- Spindle Supplied

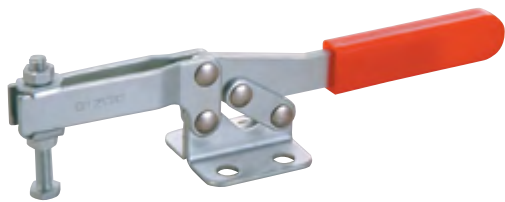

GH-25382

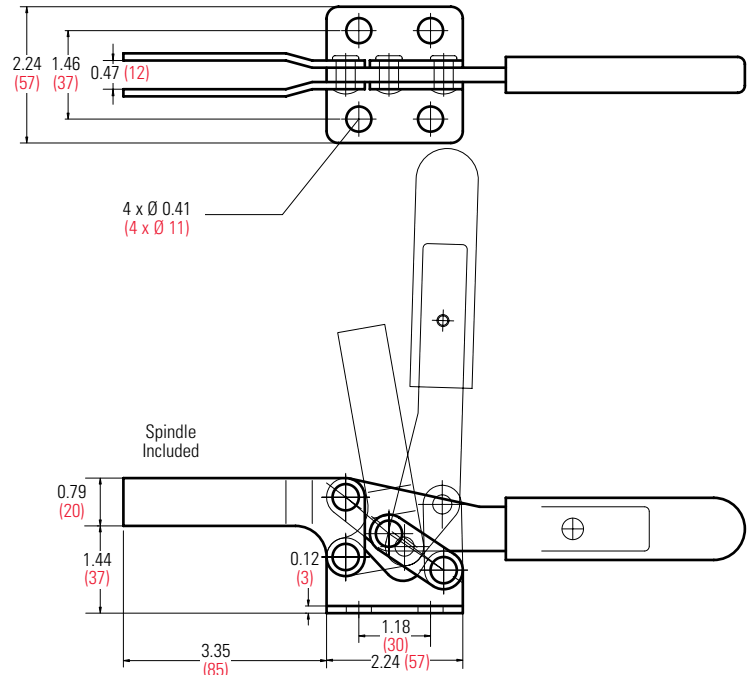

UNIT: inch (metric mm)

Series 20235

- Holding Capacity: 750 lbs. (340 kg)
- Weight: 1.41 lbs. (640 g)
- Bar opens: 85°, Handle 50°
- Spindle Supplied: GH-FC-38312



GH-20235

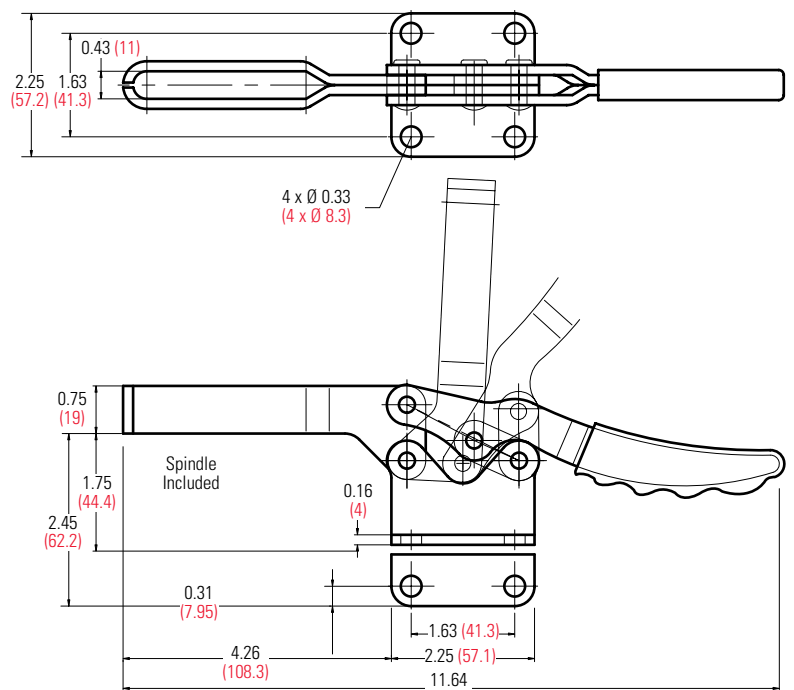

UNIT: inch (metric mm)

Model	Description
GH-20235	U-Bar, Flanged Base
GH-20235-SS	Stainless Steel Model of GH-20235
GH-20236	U-Bar, Straight Base

Series 200-W

- Holding Capacity: 880 lbs. (400 kg)
- Bar opens: 84°, Handle 85°

Woodworking models

These clamps have an extra high and long spindle bar. The 220-WH and 220-WLH have an extra lever to increase clamping leverage.

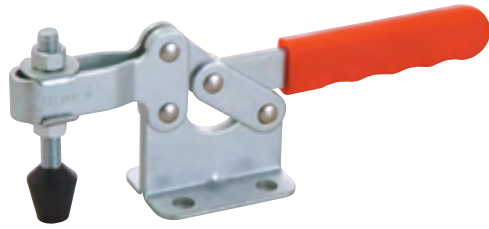

GH-200-W



GH-200-WLH

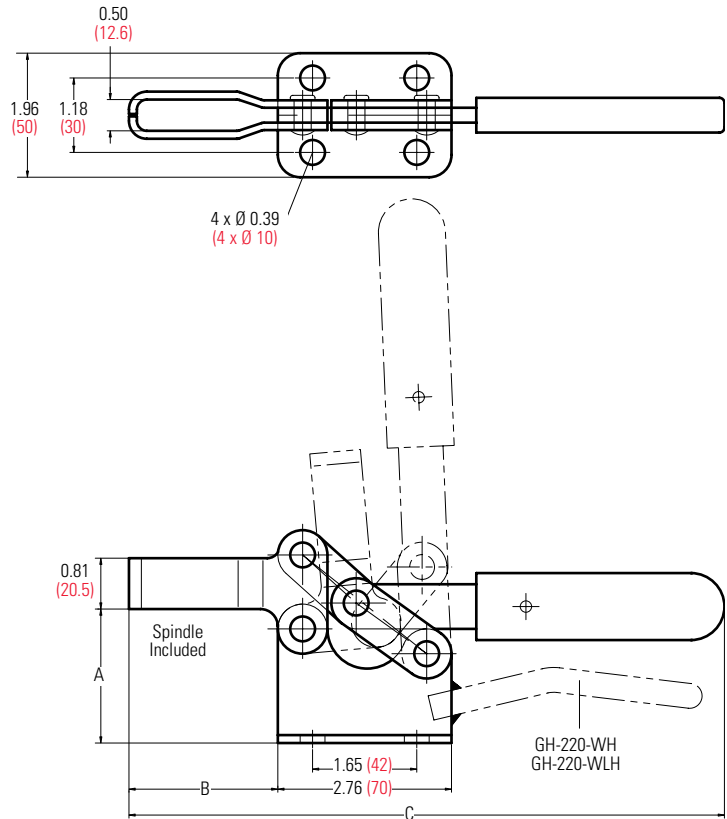

UNIT: inch (metric mm)

Model	Spindle	A	B	C	Weight
GH-200-W	GH-FC-38312	2.13 (54)	2.36 (60)	9.45 (240)	1.32 lbs. (600 g)
GH-200-WL			4.33 (110)	11.42 (290)	1.41 lbs. (640 g)
GH-200-WH	GH-FC-38412	3.11 (79)	2.36 (60)	9.45 (240)	1.54 lbs. (700 g)
GH-200-WLH			4.33 (110)	11.42 (290)	1.64 lbs. (745 g)
GH-220-WH			2.36 (60)	9.45 (240)	1.74 lbs. (790 g)
GH-220-WLH			4.33 (110)	11.42 (290)	1.83 lbs. (830 g)

UNIT: inch (metric mm)

Series 204-GB

- Holding Capacity: 1,400 lbs. (630 kg)
- Bar opens: 91°, Handle 94°
- Spindle Supplied: GH-SA-12300

This clamp is based on the GH-204-G design, without the cast iron base.

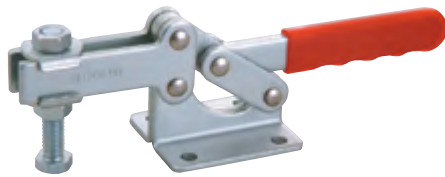

GH-204-GB



GH-204-GBLH

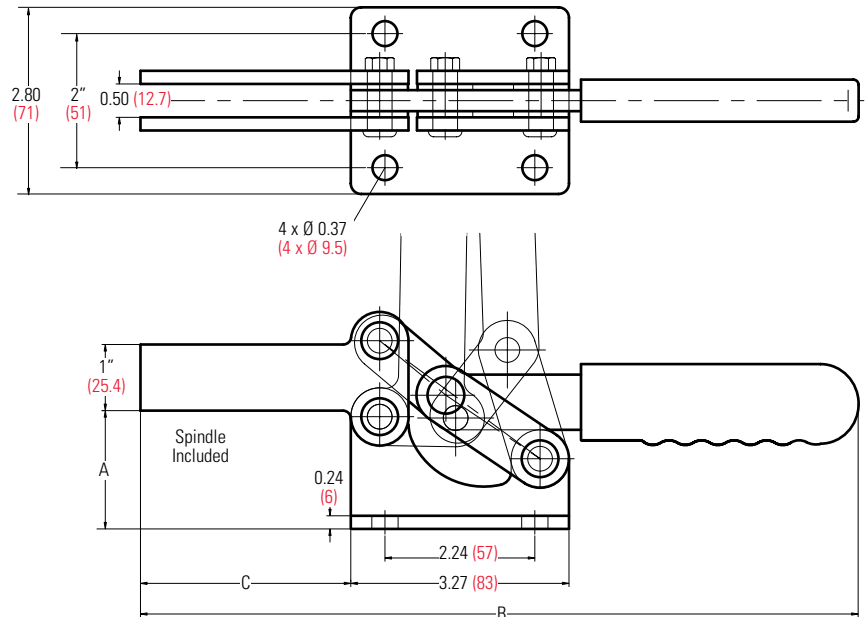

UNIT: inch (metric mm)

Model	Description	A	B	C	Weight
GH-204-GB	Short Bar, Low Base	1.77 (45)	10.59 (269)	3.15 (80)	2.60 lbs. (1,180 g)
GH-204-GBL	Long Bar, Low Base	1.77 (45)	12.44 (316)	5" (127)	2.78 lbs. (1,260 g)
GH-204-GBLH	Long Bar, High Base	2.79 (71)	12.44 (316)	5" (127)	3.23 lbs. (1,465 g)

Series 204-G

- Holding Capacity: 1,400 lbs. (636 kg)
- Weight: 2.69 lbs. (1,220 g)
- Bar opens: 91°, Handle 94°
- Spindle Supplied: GH-SA-12300

Heavy Duty Model

This clamp has five mounting holes on the cast iron base. Constructed with extra thick plate stock with hardened ground pins and bushings for smooth action and long life.

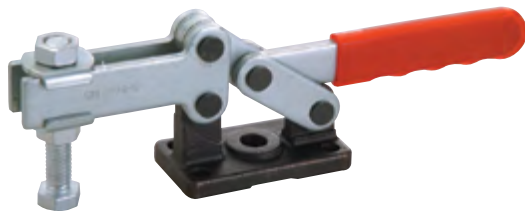

GH-204-G

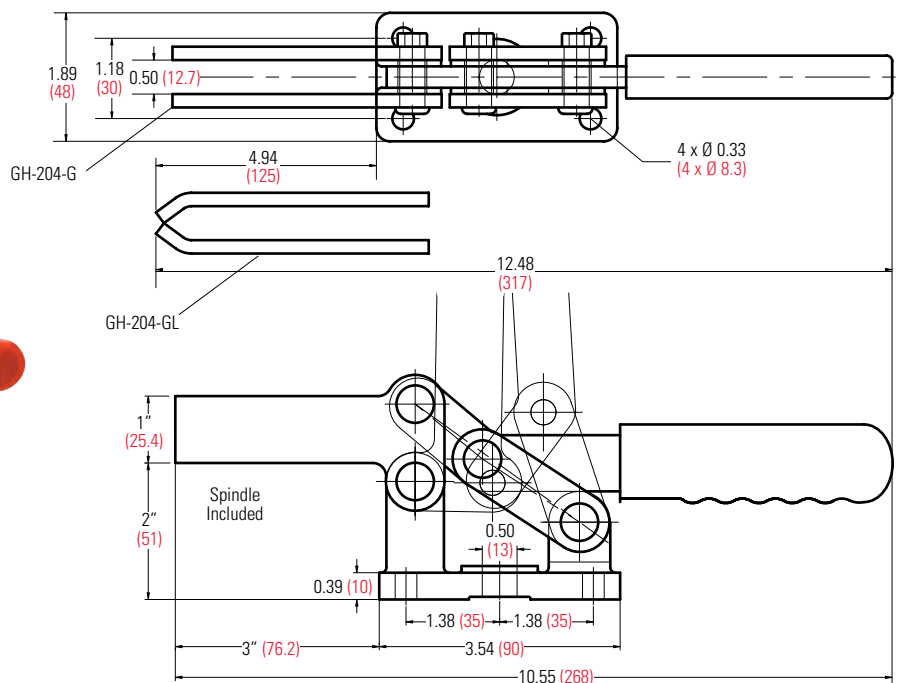

UNIT: inch (metric mm)

Model	Description
GH-204-G	Open Bar, Ductile Iron Base
GH-204-GL	Long Closed Bar, Ductile Iron Base

301-A & 301-B

- Cross Ref.: DE-STA-CO Model 601
- Holding Capacity: 100 lbs. (45 kg)
- Weight: 0.11 lb. (50 g)
- Handle opens: 190°
- Plunger stroke: 0.63" (15.9 mm)
- Spindle supplied: GH-SA-08034 (Nylon)

Economical, miniature push-pull clamp with long plunger stroke.

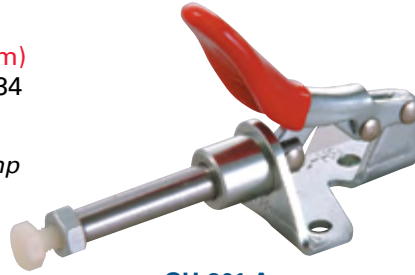

GH-301-A

Model	Description
GH-301-A	8-32 Thread
GH-301-B	1/4-20 Thread

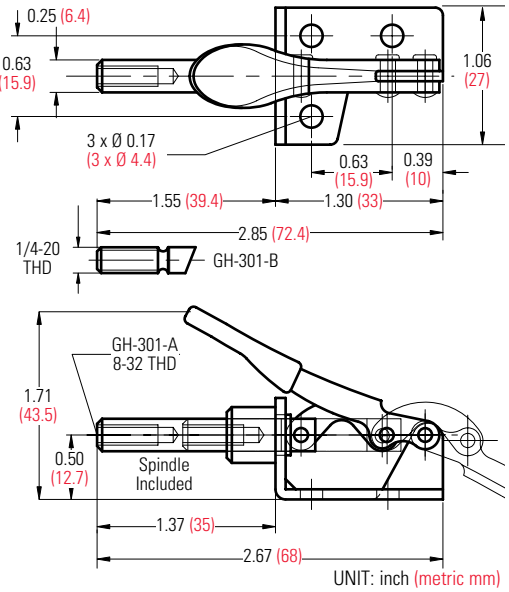

36006

- Holding Capacity: 110 lbs. (50 kg)
- Weight: 0.15 lb. (70 g)
- Handle opens: 93°
- Plunger stroke: 0.43" (11 mm)
- Spindle supplied

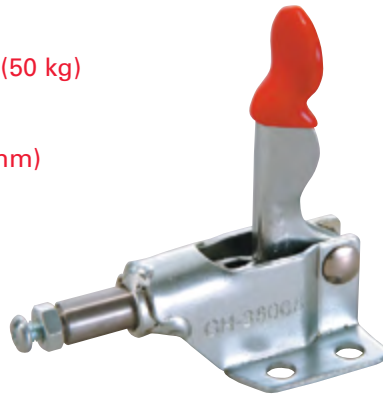

GH-36006

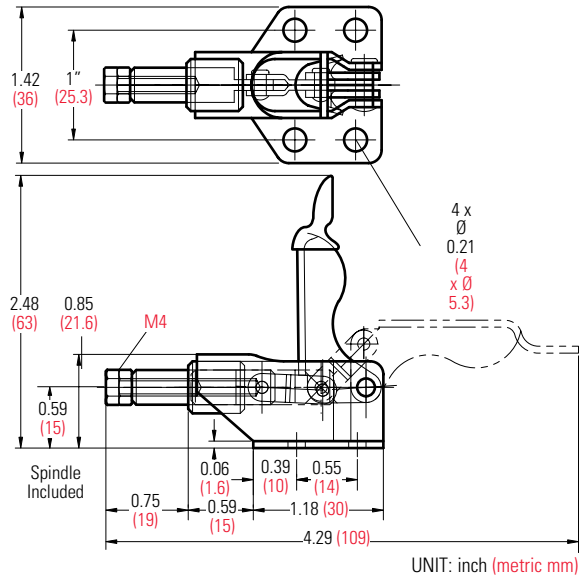

UNIQUE

36070 REVERSE ACTION

- Holding Capacity: 110 lbs. (50 kg)
- Weight: 0.22 lb. (100 g)
- Handle opens: 66°
- Plunger stroke: 0.39" (10 mm)
- Spindle supplied



GH-36070

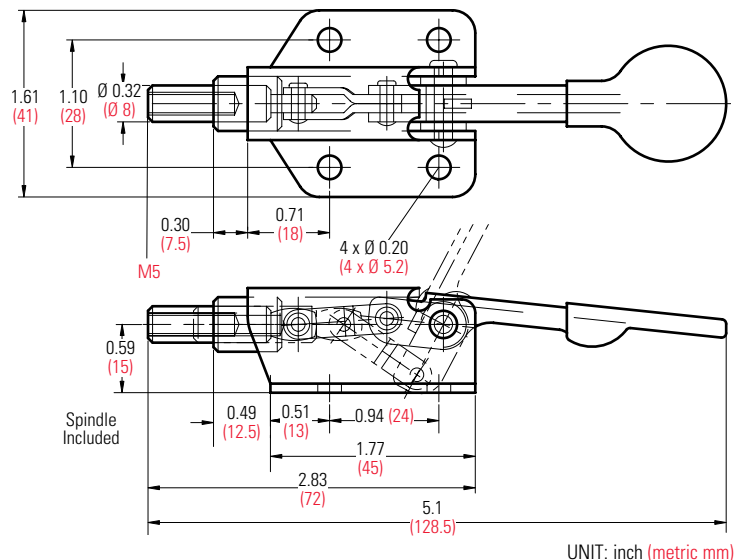

302-F & 302-FSS *Popular!*

- Cross Ref.: DE-STA-CO Model 605
- Holding Capacity: 300 lbs. (136 kg)
- Weight: 0.66 lb. (300 g)
- Handle opens: 180°
- Plunger stroke: 1.25" (32 mm)
- Spindle supplied: GH-SA-56200

The best selling mid-size push-pull clamp. Accepts all 5/16-18 spindles.



GH-302-F

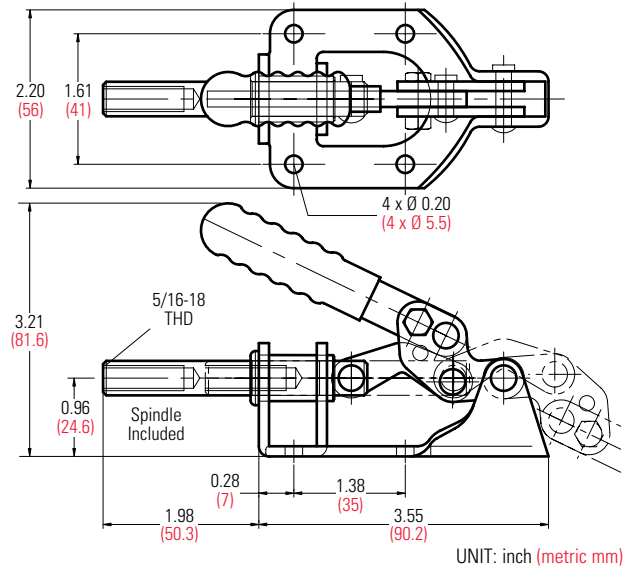

UNIQUE

302-D & 30282 *REVERSE ACTION*

- Holding Capacity: 350 lbs. (160 kg)
- Weight: 1.00 lb. (454 g)
- Handle opens: 45°
- Plunger stroke: 0.47" (12 mm)

Plunger locks in extended position only.

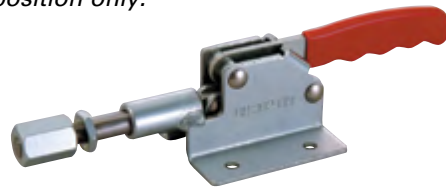

GH-302-D

Model	Description
GH-302-D	Flanged Base
GH-30282	Straight Base

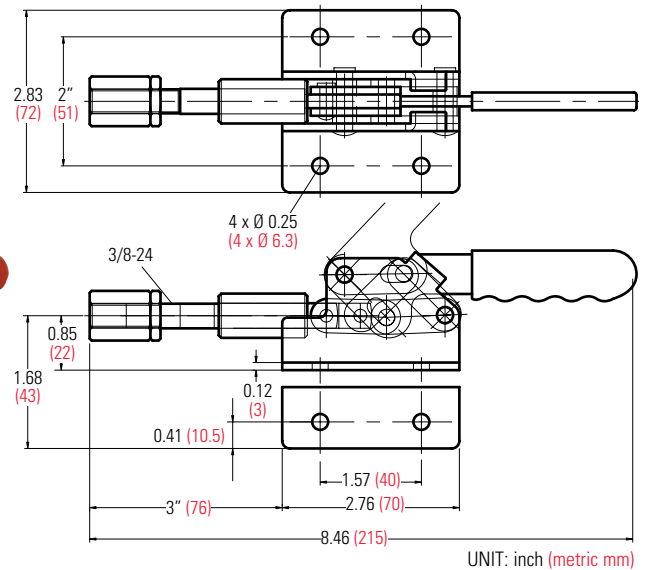

36092

- Cross Ref.: DE-STA-CO Model 609
- Holding Capacity: 400 lbs. (180 kg)
- Weight: 0.85 lb. (397 g)
- Handle opens: 180°
- Plunger stroke: 1.25" (31.8 mm)
- Spindle supplied: GH-SA-56200
- Accepts all 5/16-18 diameter spindles

Similar to GH-302-F. Addition of safety pins minimizes finger pinch.



GH-36092

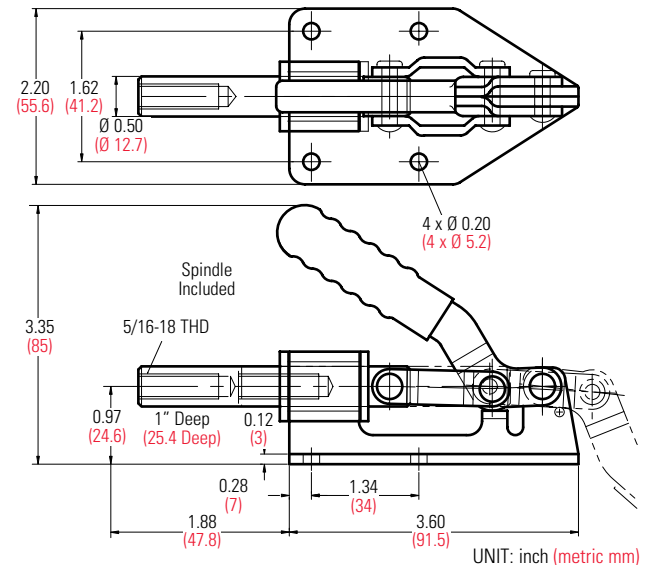

36020

- Holding Capacity: 400 lbs. (180 kg)
- Weight: 0.76 lb. (345 g)
- Handle opens: 145°
- Plunger stroke: 1.18" (30 mm)
- Spindle supplied: GH-SA-56200
- Accepts all 5/16-18 diameter spindles



GH-36020

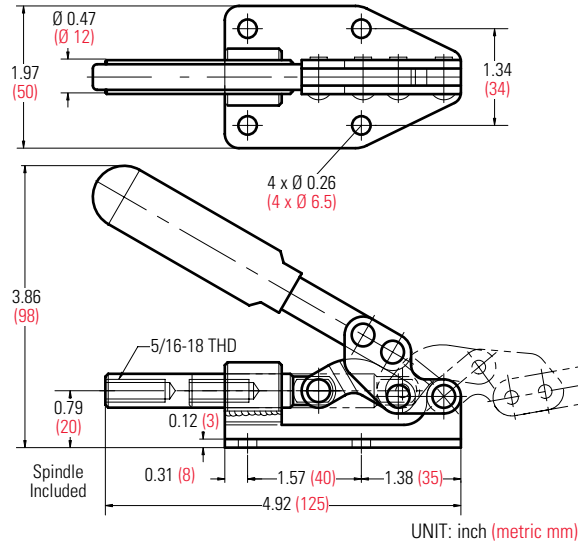

36003

- Cross Ref.: DE-STA-CO Model 603
- Holding Capacity: 600 lbs. (272 kg)
- Weight: 0.78 lb. (355 g)
- Handle opens: 180°
- Plunger stroke: 1.25" (31.8 mm)
- Spindle supplied: GH-SA-56200
- Accepts all 5/16-18 diameter spindles

This clamp has a forged alloy steel base, and lower profile handle.



GH-36003

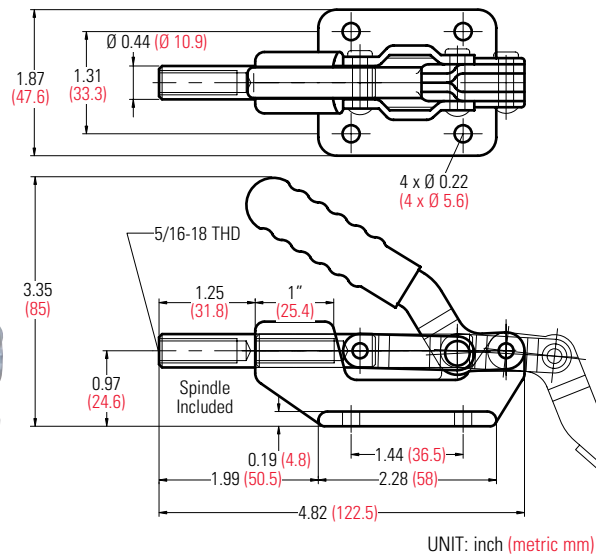

UNIQUE

30290 & 30292 REVERSE ACTION

- Holding Capacity: 650 lbs. (295 kg)
- Weight: 2.80 lbs. (1,270 g)
- Handle opens: 45°
- Plunger stroke: 0.91" (23 mm)

Plunger locks in extended position only.



GH-30290

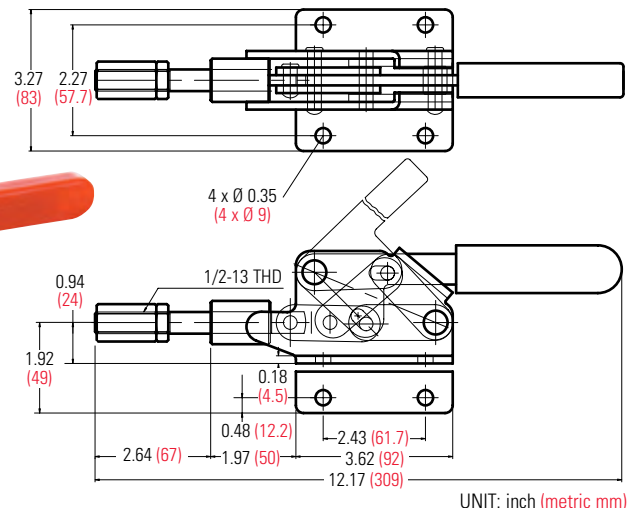

Model	Description
GH-30290	Flanged Base
GH-30292	Straight Base

UNIQUE

36060 REVERSE ACTION

- Cross Ref.: DE-STA-CO Model 620
- Holding Capacity: 660 lbs. (300 kg)
- Weight: 1.36 lbs. (615 g)
- Handle opens: 76°
- Plunger stroke: 1.10" (28 mm)
- Spindle supplied
- Accepts all **M8** diameter spindles

Plunger locks in extended position only.



GH-36060

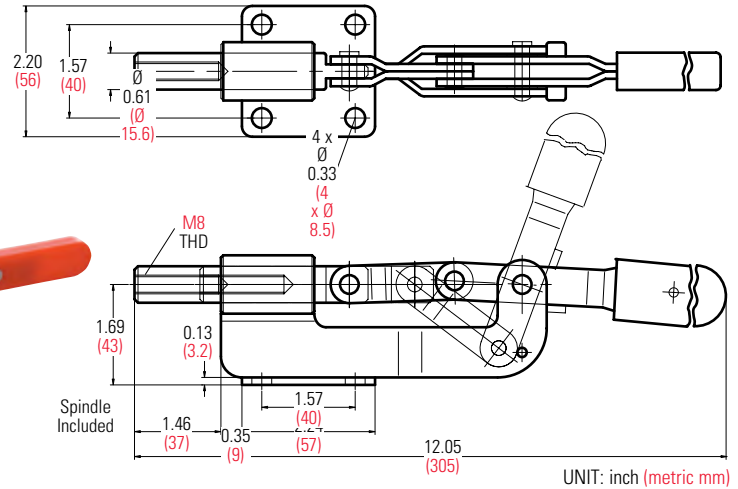

30607 LOW PROFILE

- Cross Ref.: DE-STA-CO Model 607
- Holding Capacity: 700 lbs. (318 kg)
- Weight: 1.54 lbs. (700 g)
- Handle opens: 180°
- Plunger stroke: 1.63" (41.3 mm)
- Spindle supplied: GH-SA-56200
- Accepts all 5/16-18 diameter spindles



GH-30607

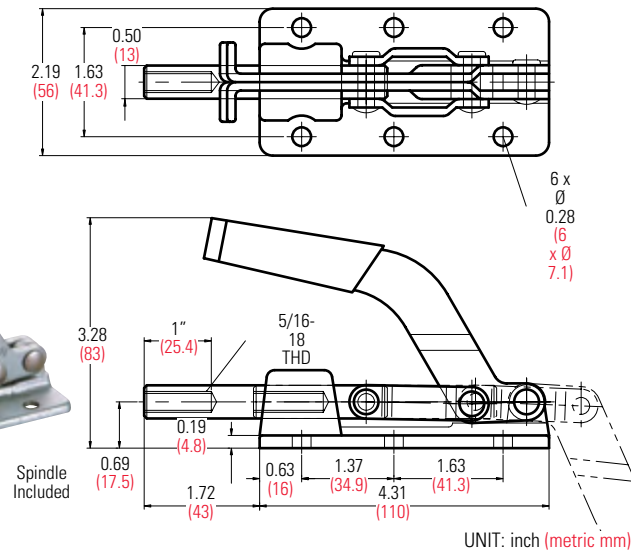

36010 & 36012

- Cross Ref.: DE-STA-CO Model 610, 618
- Holding Capacity: 800 lbs. (364 kg)
- Weight: 1.76 lbs. (800 g)
- Handle opens: 180°
- Plunger stroke: 1.63" (41.3 mm)
- Spindle supplied: GH-SA-38300
- Accepts all 3/8-16 diameter spindles

Constructed with heavy gage sheet metal, this is an economical long stroke push-pull clamp.

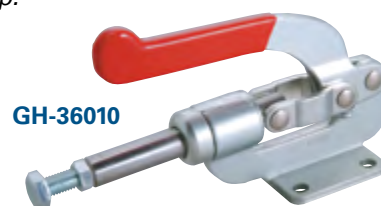

GH-36010

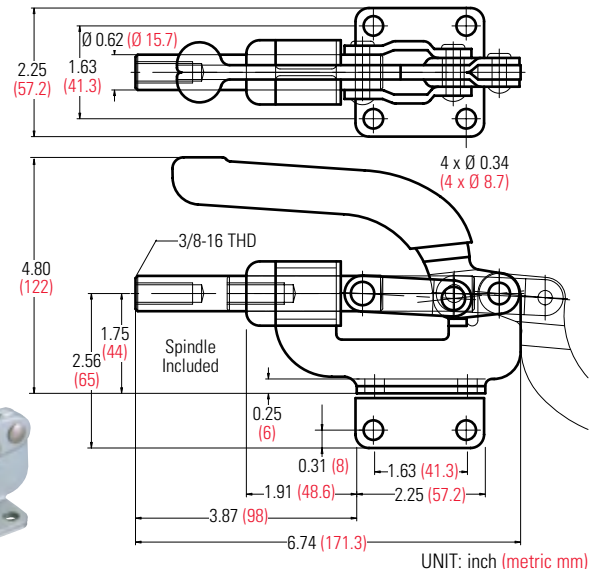

Model	Description
GH-36010	Flanged Base
GH-36012	Straight Base

303-EK

- Holding Capacity: 1,000 lbs. (454 kg)
- Weight: 2.13 lbs. (965 g)
- Handle opens: 190°
- Plunger stroke: 1.97" (50 mm)

This clamp has a key way to keep the plunger from rotating.



GH-303-EK

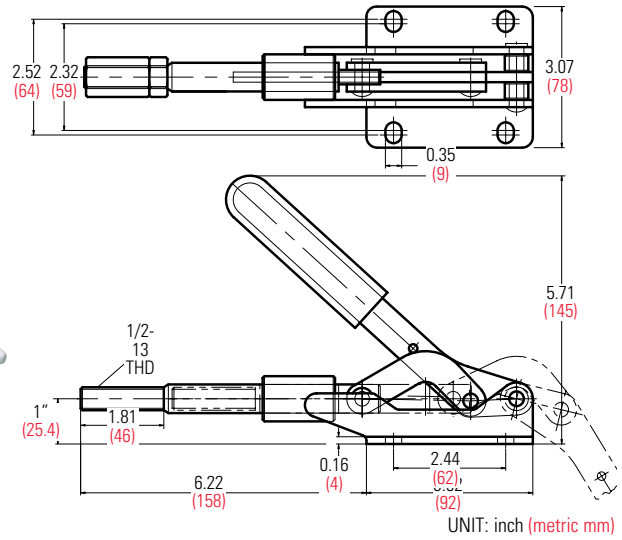

36330

- Cross Ref.: DE-STA-CO Model 630
- Holding Capacity: 2,500 lbs. (1,135 kg)
- Weight: 2.06 lbs. (935 g)
- Handle opens: 180°
- Plunger stroke: 2" (50.8 mm)
- Spindle supplied
- Accepts all 3/8-16 diameter spindles

This heavy duty clamp has a forged alloy steel base.

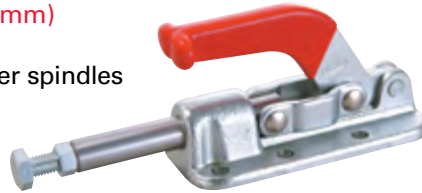

GH-36330

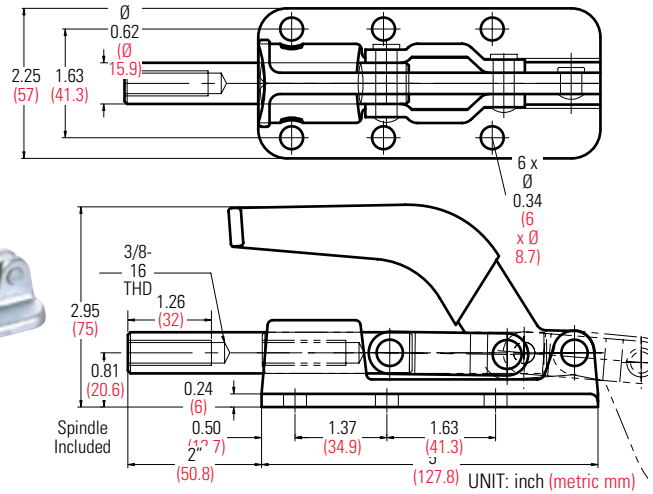

UNIQUE

30250 & 30450

This push-pull clamp has a small, special space-saving base that easily detaches for reverse positioning. Spindle Supplied.



GH-30450

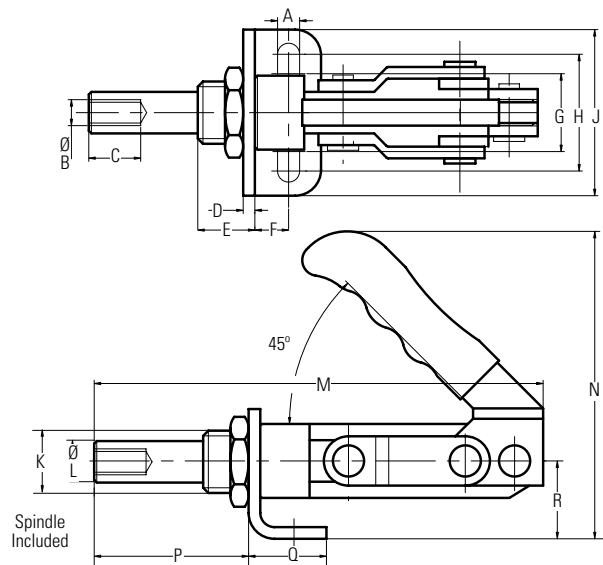

Model	Holding Capacity	Handle Opens	Plunger Stroke	A	Ø B	C	D	E	F	G	H	J	K	Ø L	M	N	P	Q	R	Weight
GH-30250	550 lbs. (250 kg)	190°	1.26 (32)	0.26 (6.5)	1/4-20	0.47 (12)	0.16 (4)	0.67 (17)	0.39 (10)	1.18 (30)	1.65 (42)	2.24 (57)	3/4-16	0.43 (11)	5.35 (136)	3.35 (85)	2" (51)	0.91 (23)	0.98 (25)	0.85 lb. (385 g)
GH-30450	990 lbs. (450 kg)	185°	1.50 (38)	0.33 (8.5)	3/8-16	0.79 (20)	0.18 (4.5)	0.87 (22)	0.51 (13)	1.18 (30)	1.77 (45)	2.52 (64)	1"-14	0.63 (16)	6.81 (173)	4.72 (120)	2.34 (60)	1.18 (30)	1.18 (30)	1.70 lbs. (774 g)

UNIT: inch (metric mm)

Series 36202

Supplied with jam nut on the work side. Spindle supplied.

All three of these plunger type push/pull clamps have threaded collars for mounting in threaded, or through holes. All clamps are supplied with thin lock nuts. Threaded mounting plates and brackets are also available as options.

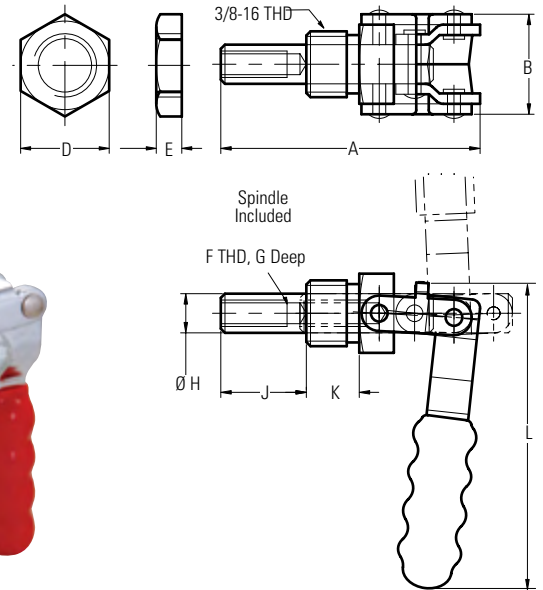

Model	Description
GH-36205	Mounting Bracket for GH-36204
GH-36225	Mounting Bracket for GH-36224

Model	Cross Ref. DE-STA-CO	Holding Capacity	Plunger Stroke	A	B	D	E	F	G	Ø H	J	K	L	T	Weight
GH-36202	602	200 lbs. (91 kg)	0.80 (20.3)	2.53 (64.3)	0.95 (24)	0.91 (23)	0.25 (6.4)	1/4-20	0.62 (15.8)	0.37 (9.4)	0.84 (21.3)	0.50 (12.7)	3.07 (78)	5/8-18	0.25 lb. (113 g)
GH-36204	604	300 lbs. (136 kg)	1.57 (40)	4.31 (109.5)	1.13 (28.6)	1" (25.4)	0.25 (6.4)	5/16-18	1" (25.4)	0.43 (10.9)	1.60 (40.7)	0.63 (16)	3.86 (98)	3/4-16	0.60 lb. (270 g)
GH-36204-SS	604-SS	Stainless Steel Model of GH-36204													
GH-36224	624	700 lbs. (318 kg)	2.63 (66.7)	6.66 (169.2)	1.57 (40)	1.48 (41)	0.25 (6.4)	3/8-16	1.26 (32)	0.63 (15.9)	2.72 (69)	0.87 (22)	5.37 (143)	1"-14	1.52 lbs. (690 g)

UNIT: inch (metric mm)

Series 304 & 305

All six of these push/pull clamps have a ductile iron base for close fit machining, strength and durability. All the shafts are ground to fit the reamed hole, so the plunger can be used for locating purposes as well as clamping. The plunger locks in both forward and retracted positions. The H model clamps are made with hardened pins and bushings for durability.

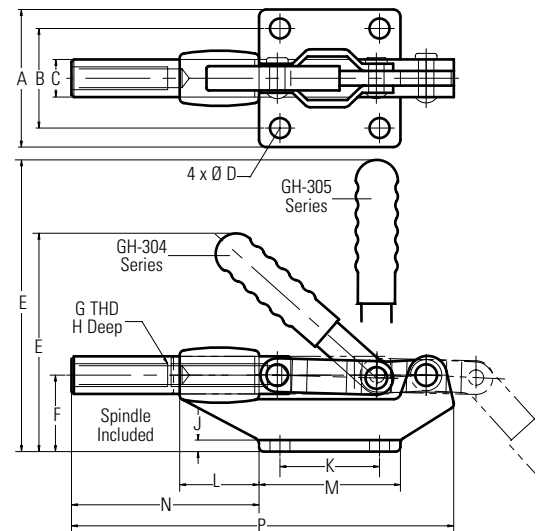

Model	Description	Holding Capacity	Spindle Supplied	Plunger Stroke	A	B	Ø C	Ø D	E	F	G	H	J	K	L	M	N	P	Weight
GH-304-C	45° Handle	500 lbs. (227 kg)	GH-SA-56200	1.26 (32)	2.25 (57.2)	1.63 (41.4)	0.50 (12.6)	0.26 (6.7)	2.94 (75)	1" (25.4)	5/16-18	1.19 (30.2)	0.19 (4.8)	1.38 (35)	0.81 (20.6)	2.06 (52.4)	2.10 (53.3)	4.94 (125.6)	0.75 lb. (340 g)
GH-305-C	90° Handle	500 lbs. (227 kg)							3.56 (91)										0.75 lb. (340 g)
GH-304-E	45° Handle	850 lbs. (386 kg)	GH-SA-38300	1.65 (42)	2.25 (57.2)	1.63 (41.4)	0.63 (15.9)	0.33 (8.3)	3.77 (95.8)	1.25 (31.8)	3/8-16	1.57 (40)	0.20 (5)	1.63 (41.4)	1.25 (31.8)	2.31 (58.8)	3.06 (77.7)	6.23 (158.2)	1.28 lbs. (580 g)
GH-305-E	90° Handle	850 lbs. (386 kg)							4.83 (123)										1.28 lbs. (580 g)
GH-304-H	45° Handle	1,500 lbs. (680 kg)	GH-SA-12300	2.36 (60)	2.81 (71.4)	2" (50.8)	0.76 (19.2)	0.33 (8.3)	5.25 (133)	1.75 (44.4)	1/2-13	1.94 (49.2)	0.25 (6.4)	2" (50.8)	2" (50.8)	2.88 (73.2)	4.76 (121)	9.38 (238)	3.26 lbs. (1,480 g)
GH-305-H	90° Handle	1,500 lbs. (680 kg)							6.76 (172)										3.26 lbs. (1,480 g)

UNIT: inch (metric mm)

Heavy Duty Models

- High strength steel construction, broached body and precise ground plunger.
- Hardened steel pins and bushings are used for pivot joints.
- Supplied with separate handle and base. Users can weld them at desired position.
- These clamps can be mounted using base (supplied) or by drilling a hole in fixture and welding in place.
- Clamp handle can be rotated to any position.

30509 & 30609

Compact design with maximum plunger travel. Plunger locks in extended position only.



GH-30509

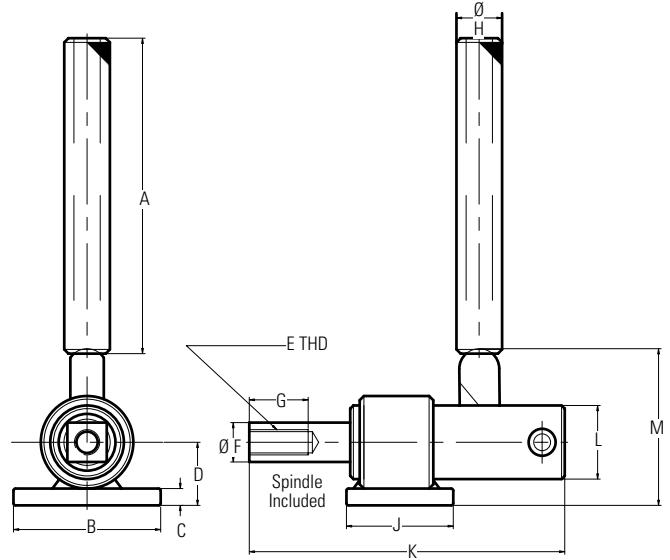

Model	Holding Capacity	Spindle Supplied	Plunger Stroke	A	B	C	D	E	Ø F	G	Ø H	J	K	L	M	Weight
GH-30509	2,500 lbs. (1,136 kg)	GH-SA-12300	1.81 (46)	6" (152.4)	2.76 (70)	0.31 (8)	1.19 (30)	1/2-13	0.75 (19)	1" (25.4)	0.85 (21.7)	2" (50.8)	5.91 (150)	1.37 (34.9)	2.91 (74)	2.93 lbs. (1,330 g)
GH-30609	5,000 lbs. (2,273 kg)	GH-SA-58500	2.34 (60)	6" (152.4)	3.56 (90.5)	0.44 (11.2)	1.58 (40)	5/8-11	1" (25.4)	1.5 (38.1)	1.07 (27.2)	2.69 (68.3)	7.80 (198)	1.75 (44.4)	3.43 (87)	6.22 lbs. (2,820 g)

UNIT: inch (metric mm)

30519 & 30619

Plunger locks at both ends of travel.



GH-30519

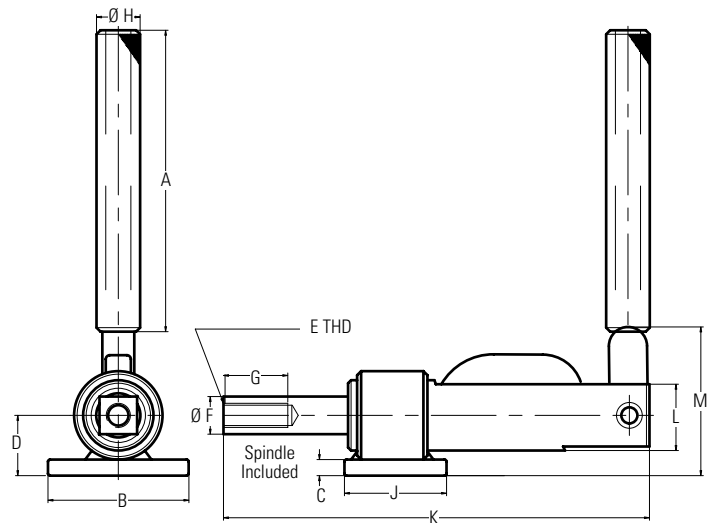

Model	Holding Capacity	Spindle Supplied	Plunger Stroke	A	B	C	D	E	Ø F	G	Ø H	J	K	L	M	Weight
GH-30519	2,500 lbs. (1,136 kg)	GH-SA-12300	2.34 (60)	6" (152.4)	2.76 (70)	0.31 (8)	1.19 (30)	1/2-13	0.75 (19)	1" (25.4)	0.85 (21.7)	2" (50.8)	8.34 (212)	1.37 (34.9)	2.91 (74)	3.62 lbs. (1,640 g)
GH-30619	5,000 lbs. (2,273 kg)	GH-SA-58500	3.06 (78)	6" (152.4)	3.56 (91)	0.44 (11.2)	1.58 (40)	5/8-11	1" (25.4)	1.5 (38.1)	1.07 (27.2)	2.69 (68.3)	11.14 (283)	1.75 (44.4)	3.43 (87)	7.72 lbs. (3,500 g)

UNIT: inch (metric mm)

Series 431

- Supplied with latch plate and standard U-bolt
- Optional Long U-Bolts available



GH-431
GH-40341

Model	Description
GH-40323-SS	Stainless Steel Model of GH-40323
GH-431-SS	Stainless Steel Model of GH-431
GH-40341-SS	Stainless Steel Model of GH-40341

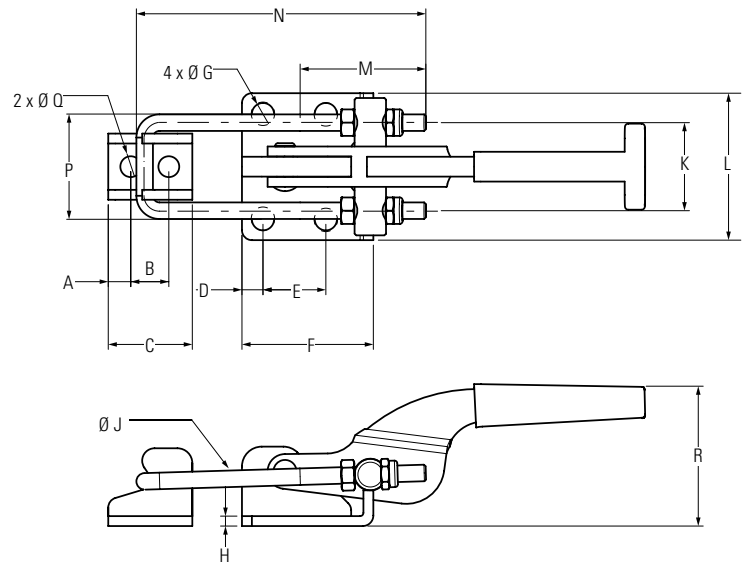

Model	Cross Ref. DE-STA-CO	Holding Capacity	A	B	C	D	E	F	Ø G	H	Ø J	K	L	M	N	P	Ø Q	R	Weight
GH-40323	323	360 lbs. (163 kg)	0.24 (6)	0.39 (9.9)	0.78 (19.8)	0.20 (5.2)	0.63 (15.9)	1.03 (26.2)	0.17 (4.4)	0.08 (2)	0.16 (4)	0.75 (19)	1.11 (28.2)	0.94 (24)	2.17 (55)	0.75 (19)	0.17 (4.4)	1.23 (31.3)	0.16 lb. (70 g)
GH-431	331	700 lbs. (318 kg)	0.27 (6.8)	0.45 (11.5)	1" (25.4)	0.25 (6.4)	0.75 (19)	1.56 (39.7)	0.26 (6.7)	0.12 (3)	0.20 (5)	1.05 (26.6)	1.75 (44.4)	1.50 (38)	3.44 (87.5)	1.25 (31.8)	0.25 (6.3)	1.67 (42.3)	0.50 lb. (225 g)
GH-40341	341	2,000 lbs. (900 kg)	0.37 (9.5)	0.75 (19.1)	1.50 (38.1)	0.37 (9.5)	1.63 (41.3)	2.37 (60.3)	0.34 (8.6)	0.16 (4)	0.31 (8)	1.75 (44.5)	2.13 (54)	2.05 (52)	4.50 (114.5)	1.50 (38.1)	0.33 (8.5)	3 (76.1)	1.5 lbs. (680 g)

UNIT: inch (metric mm)

NEW

40323-R

NEW! SECURE-LOCK MODELS!

This new model features a locking lever to securely lock the clamp in the closed position. Ideal for latching applications on molds, doors, lids, and access covers.

- Cross Ref.: DE-STA-CO Model 323-R
- Holding Capacity: 360 lbs. (163 kg)
- Weight: 0.22 lb. (100 g)



GH-40323-R

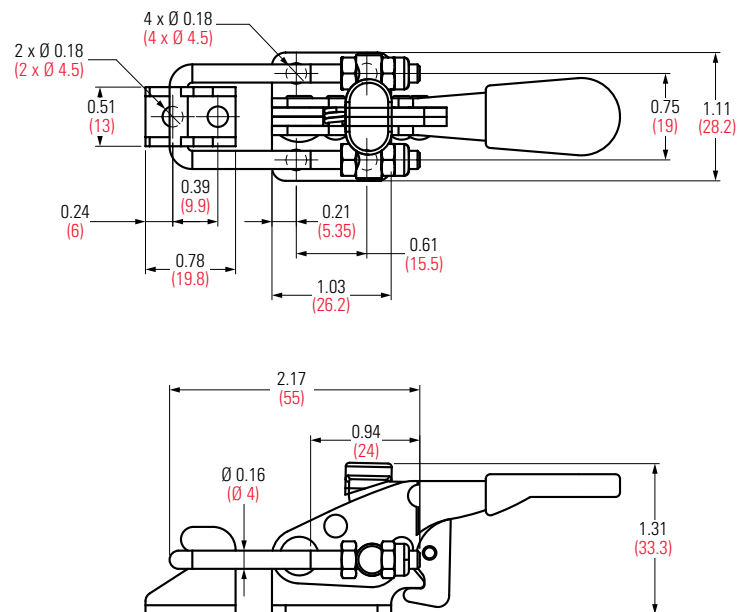

UNIT: inch (metric mm)

NEW

431-R & 40341-R

NEW! SECURE-LOCK MODELS!

This new model features a locking lever to securely lock the clamp in the closed position. Ideal for latching applications on molds, doors, lids, and access covers.

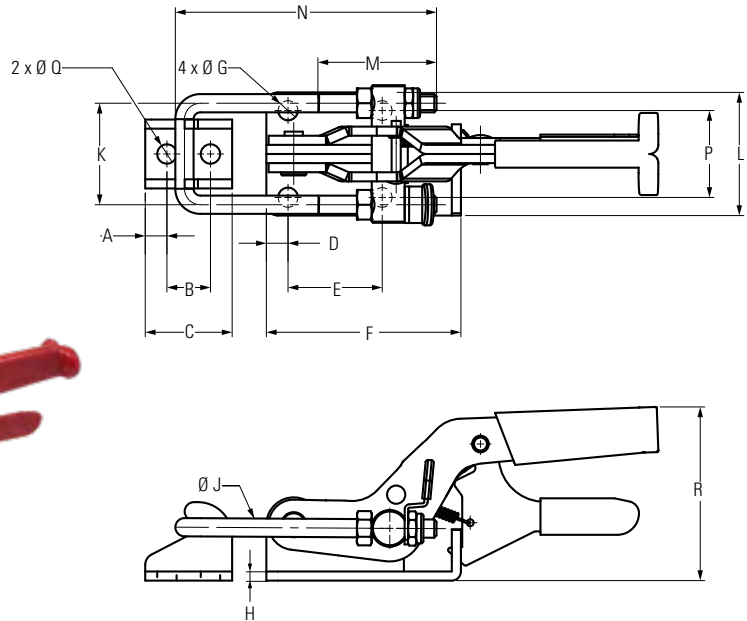

Model	Cross Ref. DE-STA-CO	Holding Capacity	A	B	C	D	E	F	Ø G	H	Ø J	K	L	M	N	P	Ø Q	R	Weight
GH-431-R	331-R	700 lbs. (318 kg)	0.27 (6.8)	0.45 (11.5)	1" (25.4)	0.25 (6.4)	0.75 (19)	1.76 (44.7)	0.26 (6.7)	0.24 (6)	0.20 (5)	1.05 (26.6)	1.75 (44.4)	1.50 (38)	3.44 (87.5)	1.25 (31.8)	0.25 (6.3)	1.81 (46)	0.59 lb. (270 g)
GH-40341-R	341-R	2,000 lbs. (900 kg)	0.37 (9.5)	0.75 (19.1)	1.50 (38.1)	0.37 (9.5)	1.63 (41.3)	3.35 (85.3)	0.34 (8.6)	0.16 (4)	0.31 (8)	1.75 (44.5)	2.13 (54)	2.05 (52)	4.51 (114.5)	1.50 (38.1)	0.33 (8.5)	3 (76.1)	1.48 lbs. (670 g)

UNIT: inch (metric mm)

UNIQUE

Optional Long U-Bolts

When you need a longer reach, you need the LUB's; Long-Reach U-Bolts for use with latches.

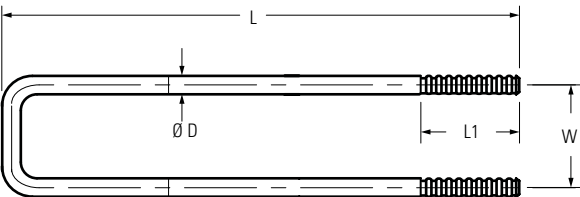

Model	Use with Model No.	L	L1	W	Ø D
GH-40323-LUB	GH-40323, GH-40323-R	2.75 (70)	1.25 (31.8)	0.75 (19)	0.16 (4.1)
GH-40323-LUBSS	Stainless Steel Model of GH-40323-LUB				
GH-431-LUB	GH-431, GH-431-R	4.5 (114)	2 (50.4)	1.25 (31.8)	0.2 (5.1)
GH-431-LUBSS	Stainless Steel Model of GH-431-LUB				
GH-40341-LUB	GH-40341, GH-40341-R	6.25 (159)	3.13 (79.5)	1.50 (38.1)	0.3 (7.6)
GH-40341-LUBSS	Stainless Steel Model of GH-40341-LUB				

UNIT: inch (metric mm)

40370

- Cross Ref.: DE-STA-CO Model 375
- Holding Capacity: 4,000 lbs. (1,818 kg)
- Weight: 2.78 lbs. (1.26 kg)

Both the alloy steel base and the **optional** latch plate are forged for strength and durability.



GH-40370-LP (Sold Separately) **GH-40370**

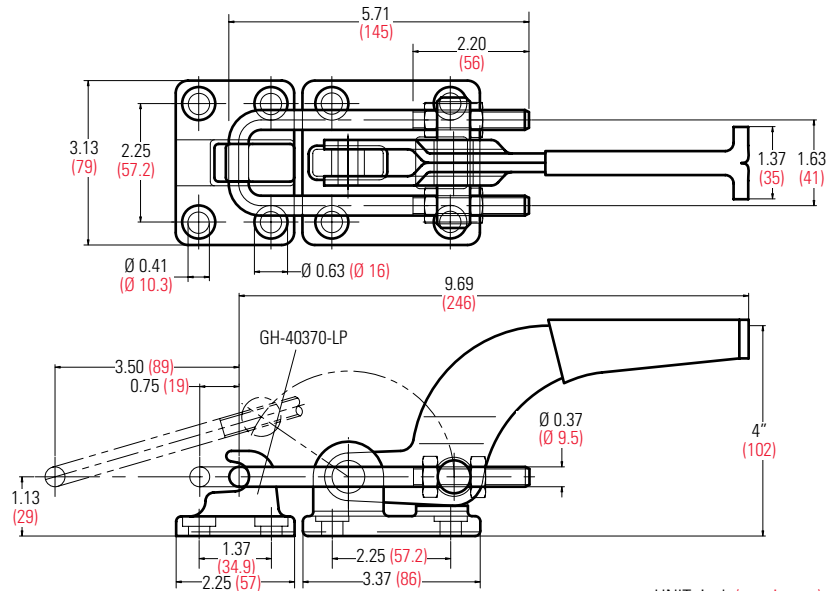

NEW
40370-R

NEW! SECURE-LOCK MODELS!
This new model features a locking lever to securely lock the clamp in the closed position. Ideal for latching applications on molds, doors, lids, and access covers.

- Cross Ref.: DE-STA-CO Model 375-R
- Holding Capacity: 4,000 lbs. (1,818 kg)
- Weight: 3.1 lbs. (1.41 kg)



GH-40370-LP (Sold Separately) **GH-40370-R**

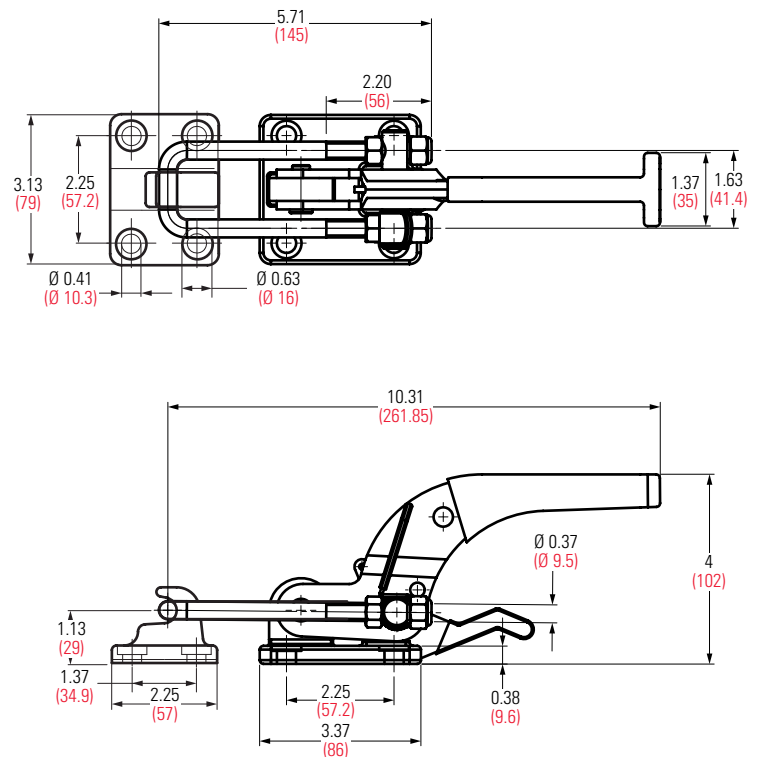

40380

- Cross Ref.: DE-STA-CO Model 385
- Holding Capacity: 7,500 lbs. (3,400 kg)
- Weight: 3.25 lbs. (1.48 kg)

This extra heavy duty model and **optional** latch plate has all forged part construction.



GH-40370-LP
(Sold Separately)

GH-40380

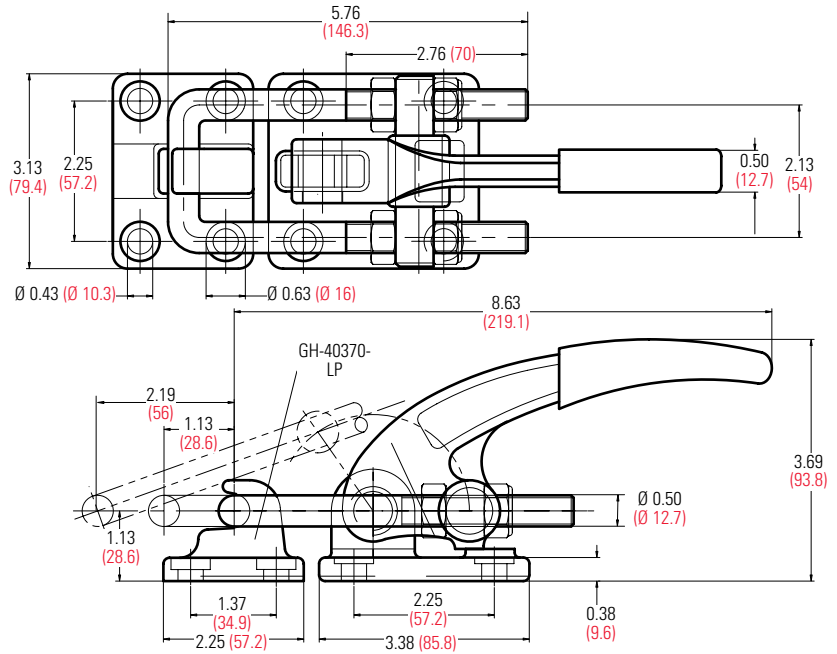

UNIT: inch (metric mm)

40370-LP

Latch Plate for Models 40370 and 40380

- Cross Ref.: DE-STA-CO Model 375509 / 385102
- Weight: 0.9 lbs. (0.4 kg)



GH-40370-LP

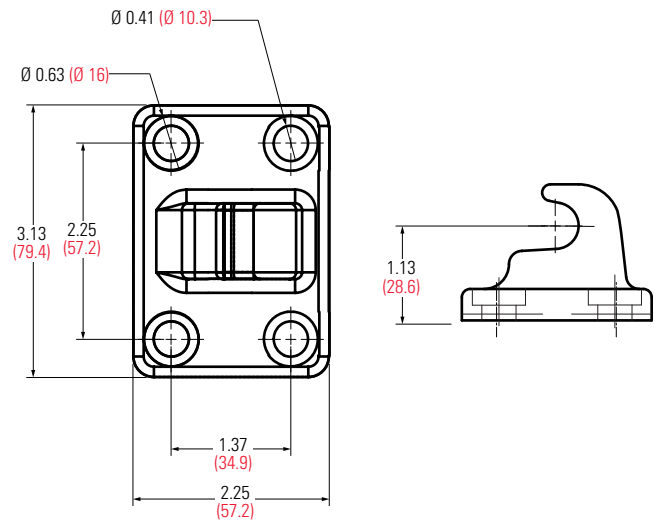

UNIT: inch (metric mm)

Series 40840

- The unique latch offers dual mounting options: **horizontal and vertical**.
- Two pivot hole patterns are provided to accommodate two mounting positions.
- Supplied latch plate offers low profile clamping for side mounting applications.

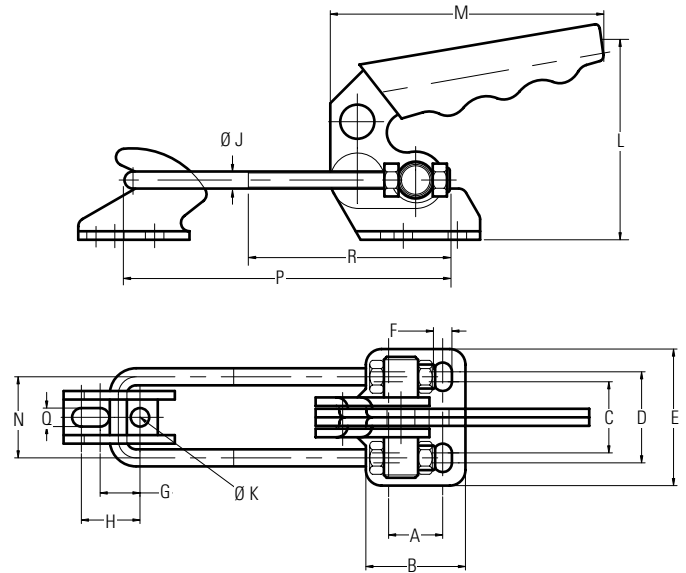

Model	Holding Capacity	A	B	C	D	E	F	G	H	ØJ	ØK	L	M	N	P	Q	R	Weight
GH-40820	440 lbs. (200 kg)	0.51 (13)	1.02 (26)	0.75 (19)	0.95 (24)	1.42 (36)	0.20 (5.2)	0.43 (11)	-	0.16 (4)	0.20 (5.2)	1.81 (46)	2.56 (65)	0.83 (21)	3.54 (90)	0.20 (5.2)	2.17 (55)	0.24 lb. (110 g)
GH-40840	550 lbs. (250 kg)	0.75 (19)	1.38 (35)	0.98 (25)	1.26 (32)	1.89 (48)	0.26 (6.5)	0.55 (14)	0.81 (20.6)	0.24 (6)	0.26 (6.5)	2.87 (73)	3.82 (97)	1.12 (28.5)	4.47 (113.5)	0.26 (6.5)	2.76 (70)	0.67 lb. (306 g)
GH-40870	1,540 lbs. (700 kg)	1.26 (32)	2" (50.5)	1.42 (36)	1.77 (45)	2.50 (63.5)	0.33 (8.5)	0.75 (19)	1.06 (27)	0.31 (8)	0.33 (8.5)	3.46 (88)	4.61 (117)	1.75 (44.5)	5.91 (150)	0.33 (8.5)	3.35 (85)	1.54 lbs. (700 g)

UNIT: inch (metric mm)

Series 40324

Supplied with latch plate

These unique latch clamps are designed for enclosure applications where the clamps are perpendicular to the latches.

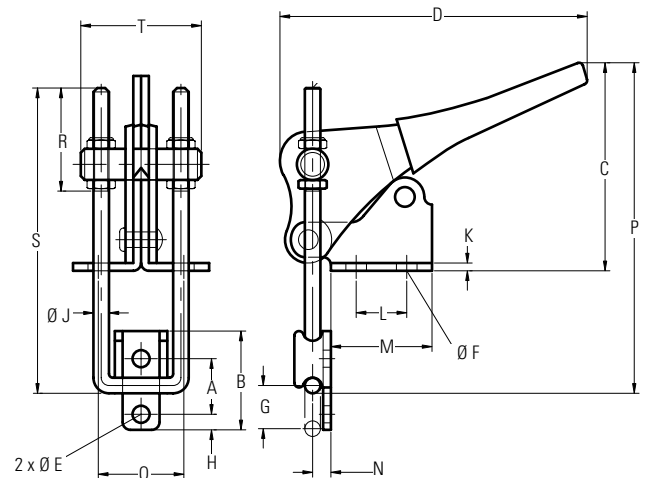
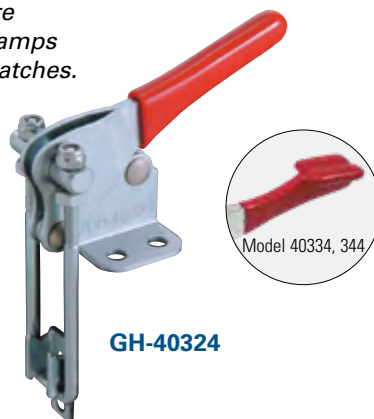

Model	Cross Ref. DE-STA-CO	Holding Capacity	A	B	C	D	ØE	ØF	G	H	ØJ	K	L	M	N	P	Q	R	S	T	Weight
GH-40324	324	500 lbs. (225 kg)	0.56 (14.3)	1" (25.4)	2.09 (53.3)	3.11 (79)	0.17 (4.4)	0.21 (5.3)	0.44 (11.1)	0.16 (4)	0.16 (4)	0.08 (2)	0.51 (13)	1.02 (26)	0.19 (4.7)	2.76 (70)	0.87 (22)	1.04 (26.5)	3.09 (78.5)	1.22 (31)	0.25 lb. (113 g)
GH-40334	334	1,000 lbs. (450 kg)	0.81 (20.6)	1.50 (38.1)	2.57 (65.4)	4.79 (122)	0.22 (5.6)	0.28 (7.1)	0.39 (17.5)	0.28 (7.1)	0.24 (6)	0.12 (3)	0.75 (19.1)	1.31 (33.3)	0.34 (8.7)	4.21 (107)	1.10 (28)	1.59 (40.5)	4.37 (111)	1.63 (41.3)	0.56 lb. (250 g)
GH-40344	344	2,000 lbs. (900 kg)	1.06 (27)	2.13 (54)	3.31 (84.1)	5.13 (130)	0.34 (8.7)	0.34 (8.7)	1.13 (28.6)	0.37 (9.5)	0.31 (7.9)	0.16 (4)	1.25 (31.8)	1.87 (47.6)	0.50 (12.7)	5.91 (150)	1.44 (36.5)	2.28 (58)	6.06 (154)	2.37 (60.3)	1.54 lbs. (700 g)

UNIT: inch (metric mm)

NEW

40324-R, 40334-R & 40344-R

NEW! SECURE-LOCK MODELS!

This new model features a locking lever to securely lock the clamp in the closed position. Ideal for latching applications on molds, doors, lids, and access covers.



GH-40334-R
GH-40344-R

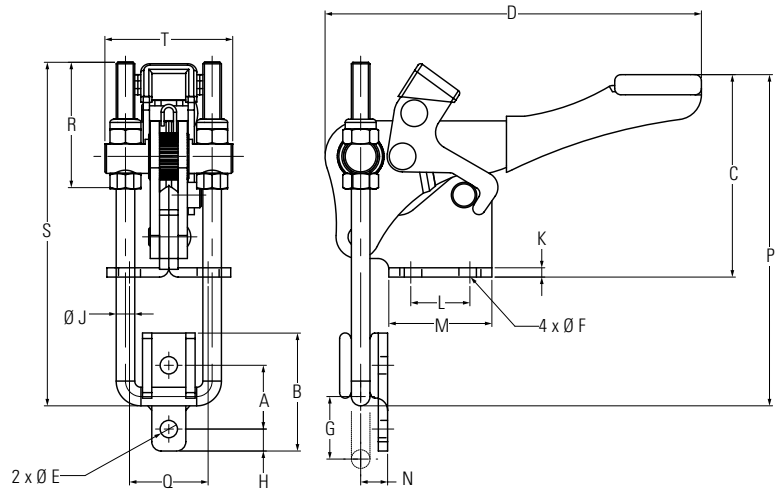

Model	Cross Ref. DE-STA-CO	Holding Capacity	A	B	C	D	Ø E	Ø F	G	H	Ø J	K	L	M	N	P	Q	R	S	T	Weight
GH-40324-R	324-R	500 lbs. (225 kg)	0.56 (14.3)	1" (25.4)	2.23 (56.7)	3.11 (79)	0.17 (4.4)	0.21 (5.3)	0.44 (11.1)	0.16 (4)	0.16 (4)	0.08 (2)	0.51 (13)	1.02 (26)	0.19 (4.7)	2.76 (70)	0.87 (22)	1.04 (26.5)	3.09 (78.5)	1.22 (31)	0.26 lb. (120 g)
GH-40334-R	334-R	1,000 lbs. (450 kg)	0.81 (20.6)	1.50 (38.1)	2.57 (65.4)	4.79 (122)	0.22 (5.6)	0.28 (7.1)	0.39 (17.5)	0.28 (7.1)	0.24 (6)	0.12 (3)	0.75 (19.1)	1.31 (33.3)	0.34 (8.7)	4.21 (107)	1.10 (28)	1.59 (40.5)	4.37 (111)	1.63 (41.3)	0.7 lb. (320 g)
GH-40344-R	344-R	2,000 lbs. (900 kg)	1.06 (27)	2.13 (54)	3.31 (84.1)	5.13 (130)	0.34 (8.7)	0.34 (8.7)	1.13 (28.6)	0.37 (9.5)	0.31 (7.9)	0.16 (4)	1.25 (31.8)	1.87 (47.6)	0.50 (12.7)	5.91 (150)	1.44 (36.5)	2.28 (58)	6.06 (154)	2.37 (60.3)	1.76 lbs. (800 g)

UNIT: inch (metric mm)

Series 451

These are the most popular latch clamps with adjustable single hook design. Model GH-451 has a flanged base, while Model GH-452 has a narrow base which is less tolerant to twisting motions. Stainless steel models are available. Optional Latch Plates are also available.

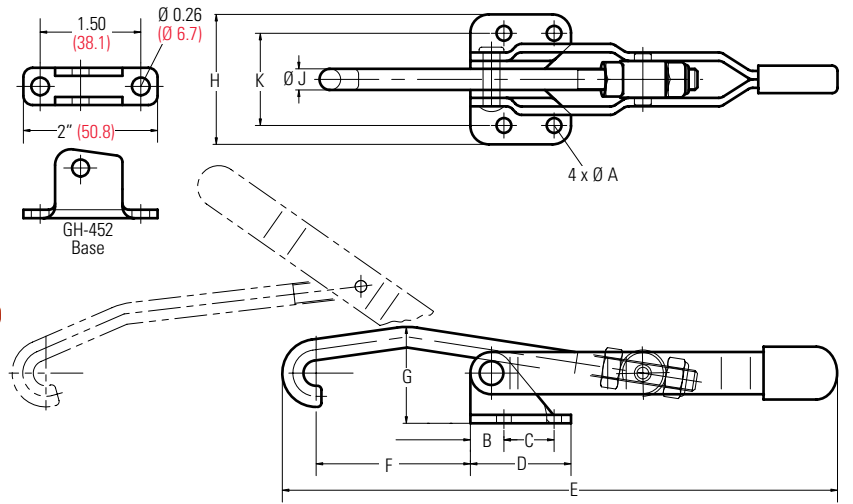
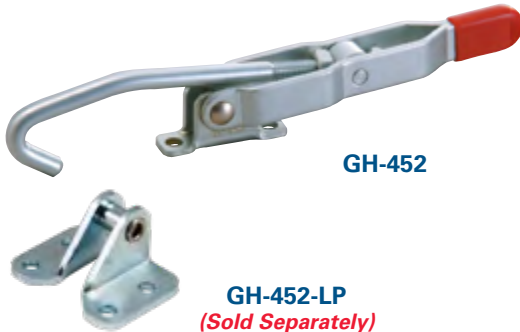

UNIT: inch (metric mm)

Model	Cross Ref.: DE-STA-CO	Description	Holding Capacity	Ø A	B	C	D	E	F	G	H	Ø J	K	Weight	Optional Latch Plate
GH-451	351	Flanged Base	375 lbs. (170 kg)	0.22 (5.6)	0.50 (12.7)	0.75 (19)	1.50 (38.1)	8.35 (212)	2.30 (58.3)	1.44 (36.5)	1.94 (49.2)	0.31 (8)	1.37 (34.9)	0.59 lb. (270 g)	GH-451-LP
GH-451-SS	351-SS	Stainless Steel Model of GH-451													GH-451-LPSS
GH-452	351-B	Narrow Base	375 lbs. (170 kg)	0.26 (6.7)	-	1.50 (38.1)	2" (50.8)	8.31 (211)	1.76 (44.8)	1.44 (36.5)	-	0.31 (8)	-	0.56 lb. (255 g)	GH-452-LP
GH-452-SS	351-BSS	Stainless Steel Model of GH-452													GH-452-LPSS
GH-40371	371	Flanged Base	750 lbs. (340 kg)	0.34 (8.7)	0.31 (7.9)	1.25 (31.8)	1.87 (47.6)	11.22 (285)	3.13 (79.4)	2.25 (57.3)	2.59 (65.7)	0.37 (9.5)	1.94 (49.2)	1.38 lbs. (624 g)	GH-40371-LP
GH-43810	381	Flanged Base	1,000 lbs. (450 kg)	0.41 (10.3)	0.50 (12.7)	1.13 (28.6)	2.13 (54)	13.23 (336)	3" (76.2)	2.68 (68)	3.37 (85.7)	0.50 (12.7)	2.37 (60.3)	2.56 lbs. (1,130 g)	GH-43810-LP

UNIT: inch (metric mm)

43101

- Cross Ref.: DE-STA-CO Model 301
- Holding Capacity: 375 lbs. (170 kg)
- Weight: 0.68 lb. (310 g)
- Optional latch plate model GH-43101-LP

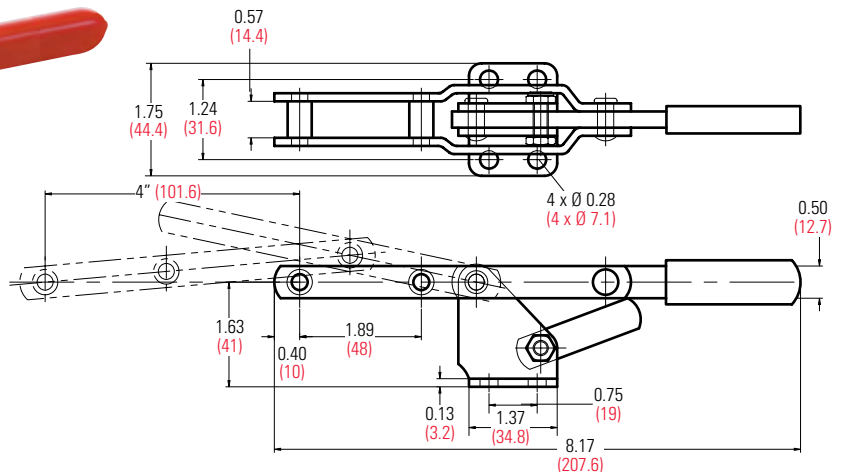
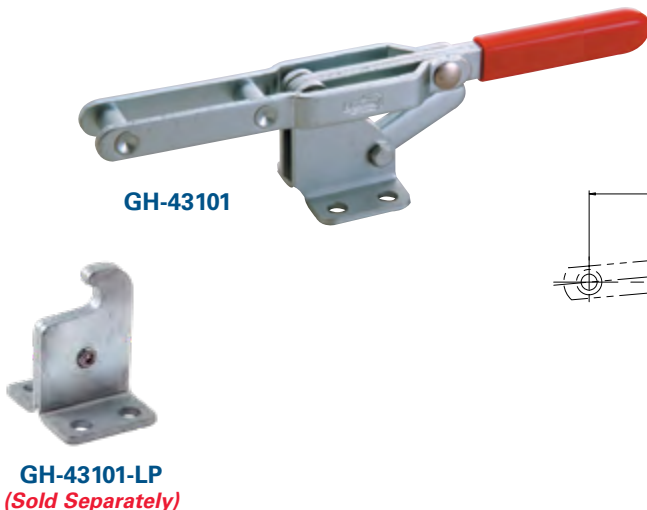

UNIT: inch (metric mm)

43110 & 43120

- Holding Capacity: 375 lbs. (170 kg)
- Weight: 0.40 lb. (180 g)
- GH-43110 supplied with M6 hook bolt
- GH-43120 supplied with hex head spindle assembly.



GH-43110



GH-43120

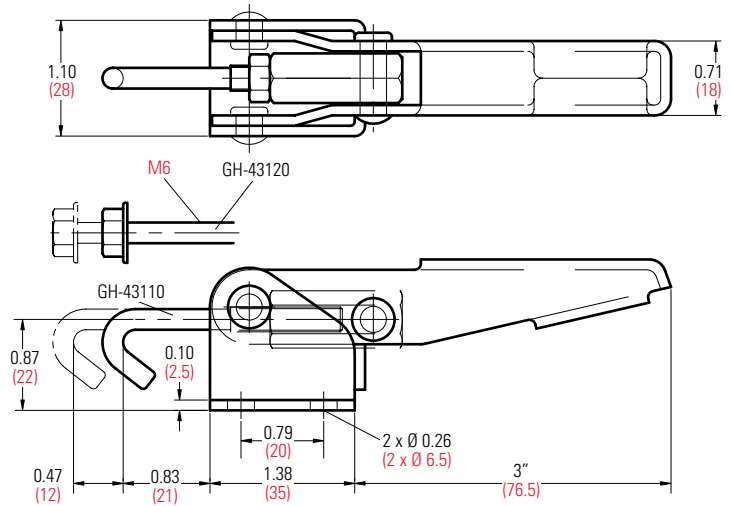

UNIT: inch (metric mm)

43150 & 43160

- Holding Capacity: 660 lbs. (300 kg)
- Weight: 0.85 lb. (385 g)
- GH-43150 supplied with M10 hook bolt
- GH-43160 supplied with hex head spindle assembly.



GH-43150



GH-43160

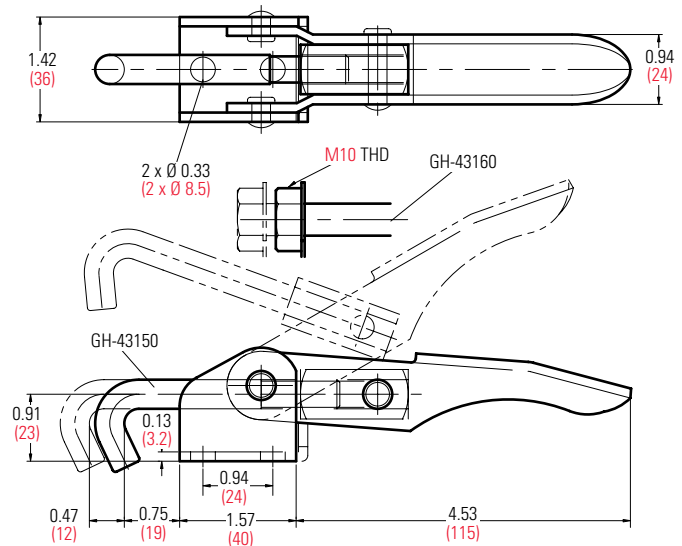

UNIT: inch (metric mm)

All Pliers are forged from alloy steel with stainless steel rivets for durability.

50350

- Cross Ref.: DE-STA-CO Model 424
- Holding Capacity: 200 lbs. (90 kg)
- Weight: 0.41 lb. (185 g)
- Spindle Supplied: GH-SA-14112

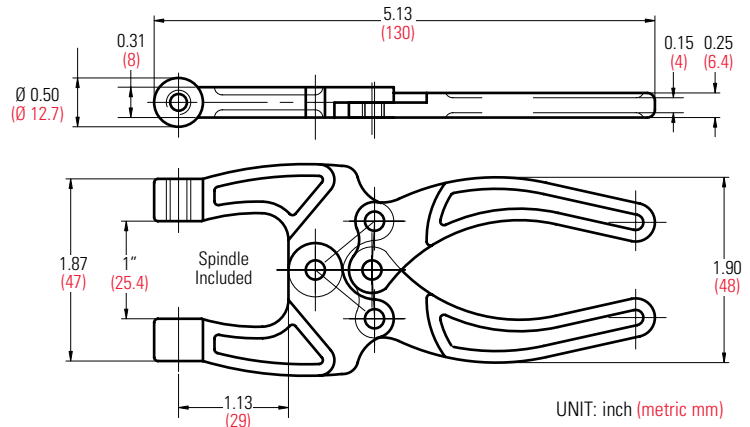

50360

- Cross Ref.: DE-STA-CO Model 441
- Holding Capacity: 350 lbs. (159 kg)
- Weight: 0.64 lb. (290 g)
- Spindle Supplied: GH-SA-56200

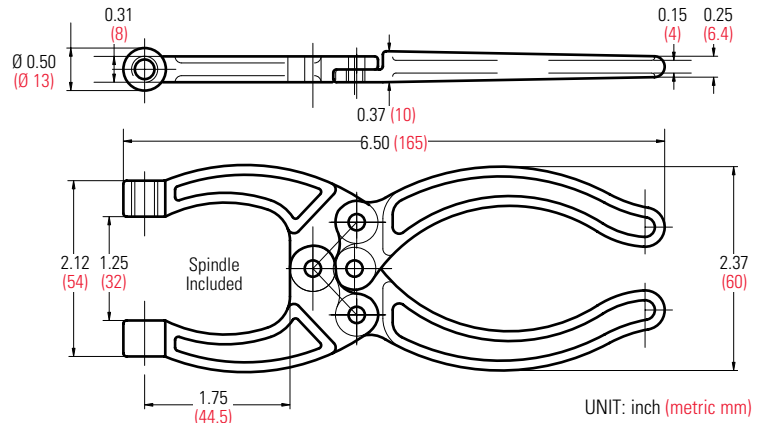

50380

- Cross Ref.: DE-STA-CO Model 462
- Holding Capacity: 700 lbs. (318 kg)
- Weight: 1.46 lbs. (660 g)
- Spindle Supplied: GH-SF-38300

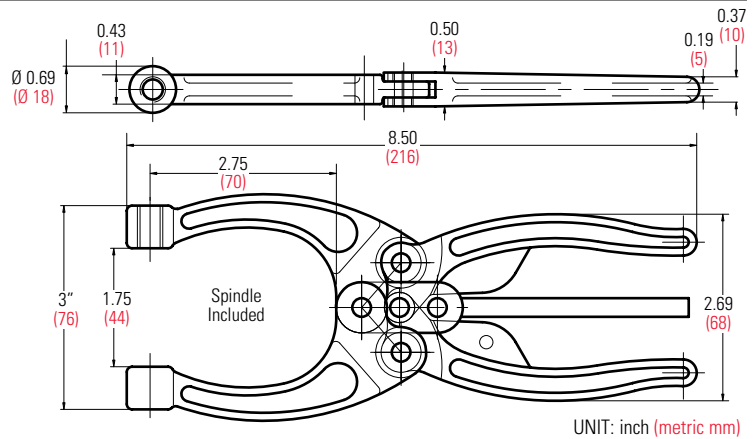

50385

- Holding Capacity: 1,800 lbs. (820 kg)
- Weight: 1.56 lbs. (710 g)
- Spindle Supplied: GH-SA-38114

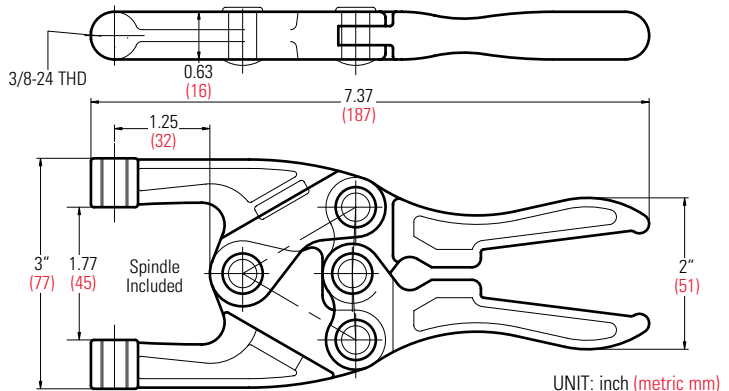

61352

- Holding Capacity: 200 lbs. (90 kg)
- Weight: 0.3 lb. (130 g)
- Spindle Supplied: GH-SA-14112

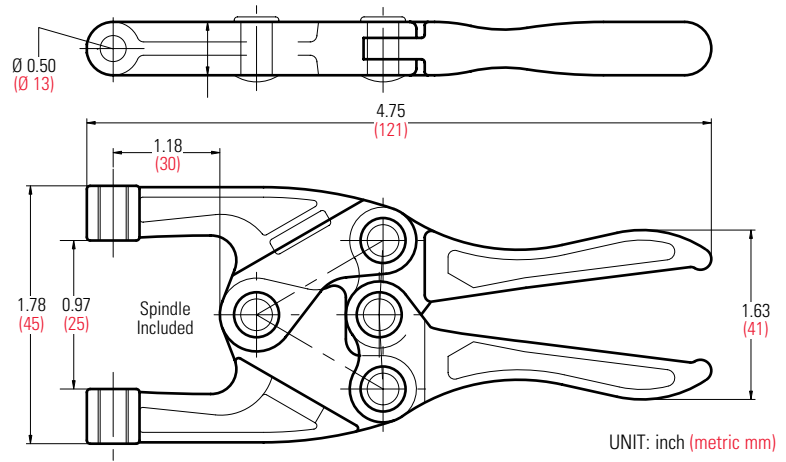

50450

- Cross Ref.: DE-STA-CO Model 463
- Holding Capacity: 700 lbs. (318 kg)
- Weight: 1.63 lbs. (740 g)
- Spindle Supplied: GH-SF-38300 swivel foot and GH-SA-38300 hex head spindle assembly

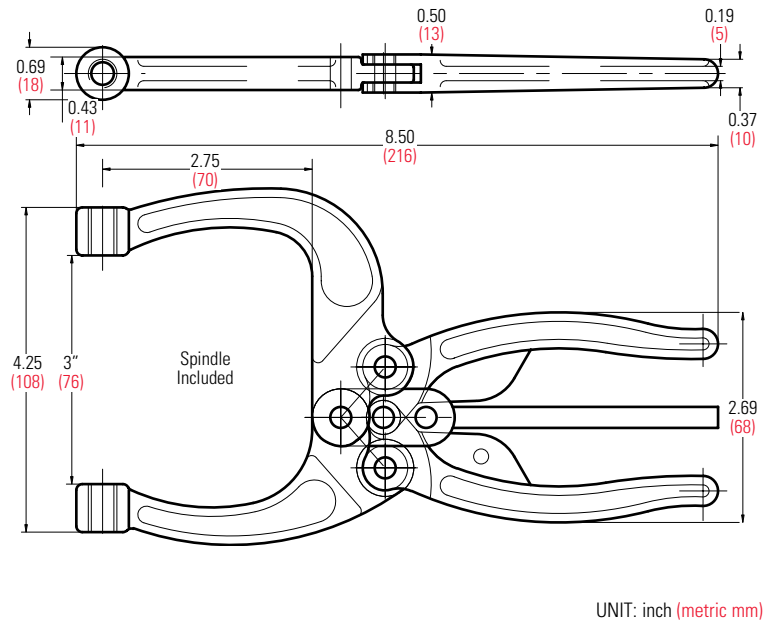

60130 & 60131

- Designed to hold work-piece with inconsistent height.
- Cam Action permits hold down material deviation of 0.125" (3.2 mm) in height.
- Ideal for castings and forgings, etc.

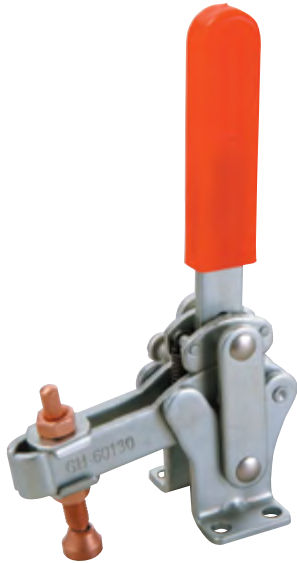

GH-60130

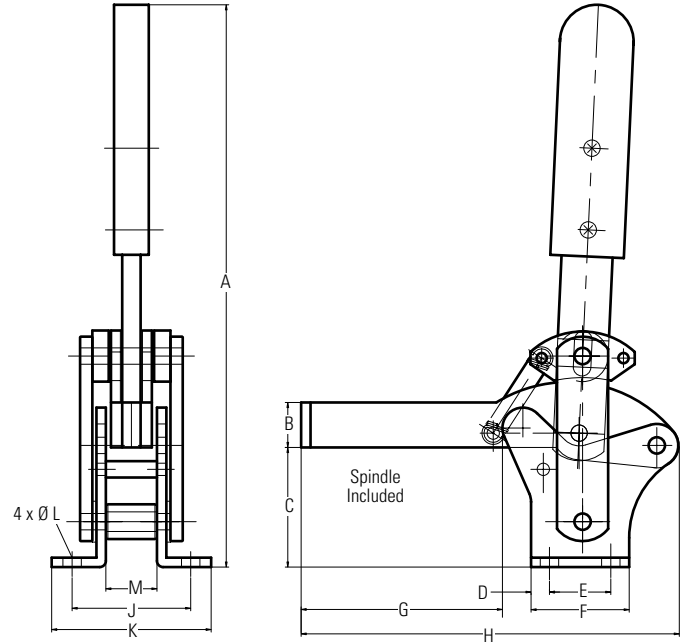

Model	Holding Capacity	Spindle Supplied	Bar Opens	Handle Opens	A	B	C	D	E	F	G	H	J	K	Ø L	M	Weight
GH-60130	550 lbs. (250 kg)	GH-SF-38300	70°	165°	8.66 (220)	0.75 (19)	1.54 (39)	0.25 (6.5)	0.87 (22)	1.38 (35)	2.28 (58)	4.65 (118)	1.89 (48)	2.44 (62)	0.31 (8)	0.79 (20)	1.50 lbs. (680 g)
GH-60131	770 lbs. (350 kg)	GH-SF-12400	85°	170°	10.83 (275)	0.87 (22)	2.36 (60)	0.35 (9)	1.18 (30)	1.89 (48)	3.94 (100)	7" (178)	2.24 (57)	3.03 (77)	0.35 (9)	0.98 (25)	3.51 lbs. (1,590 g)

UNIT: inch (metric mm)

These heavy-duty clamps provide the strong, durable holding power to meet the requirements of the auto industry. These clamps are forged from alloy steel, hardened, and ground to close tolerance. Pins are also hardened and grounded. A separate handle is included with each clamp for welding in the desired position.

Series 701 & 702

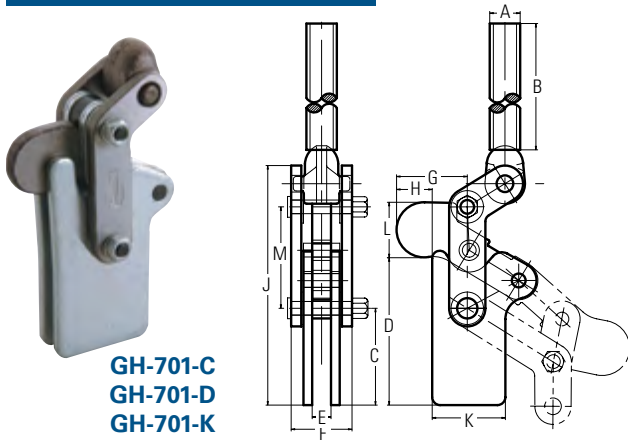

GH-701-C
GH-701-D
GH-701-K

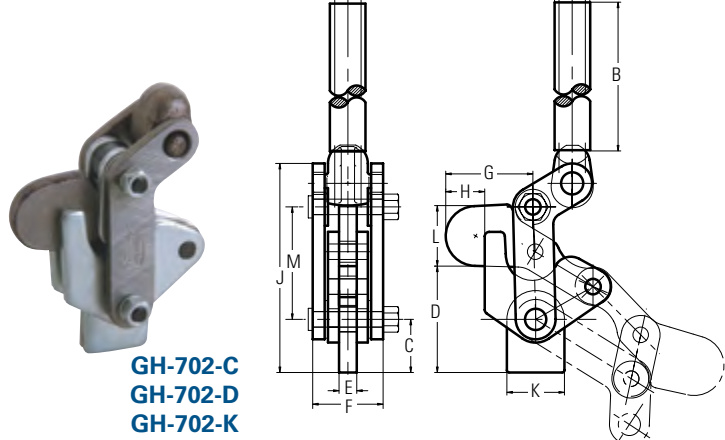

GH-702-C
GH-702-D
GH-702-K

Model	Holding Capacity	Arm Opens	Handle Opens	Ø A	B	C	D	E	F	G	H	J	K	Ø L	M	Weight	
GH-701-C	440 lbs. (200 kg)	194°	123°	0.68 (17.3)	6" (152.4)	1.96 (50)	0.57 (14.5)	0.31 (8)	1.25 (31.8)	1.57 (40)	0.67 (17)	4.75 (121)	1.75 (44.5)	1.10 (28)	2" (50.8)	1.32 lbs. (598 g)	
GH-701-D	1,100 lbs. (500 kg)	191°	122°	0.85 (21.7)		2.69 (66.8)	4" (102)	0.51 (13)	1.65 (42)	1.92 (48.8)	0.97 (24.6)	6.50 (165)	1.97 (50)	1.54 (39)	1.54 (39)	2.75 (70)	3.50 lbs. (1,587 g)
GH-701-K	2,200 lbs. (1,000 kg)	197°	128°	1.07 (27.2)		3.15 (80)	4.84 (123)	0.63 (16)	1.81 (46)	2.09 (53)	0.98 (25)	8.07 (205)	2.48 (63)	2.05 (52)	3.54 (90)	5.84 lbs. (2,650 g)	
GH-702-C	440 lbs. (200 kg)	194°	123°	0.68 (17.3)		0.94 (23.8)	1.89 (48)	0.31 (8)	1.25 (31.8)	1.57 (40)	0.67 (17)	3.66 (93)	1.02 (26)	1.10 (28)	2" (50.8)	1.50 lbs. (680 g)	
GH-702-D	1,100 lbs. (500 kg)	191°	122°	0.85 (21.7)		1.33 (33.7)	2.72 (69)	0.51 (13)	1.65 (42)	1.92 (48.8)	0.97 (24.6)	5.20 (132)	1.43 (36.4)	1.54 (39)	2.75 (70)	3.24 lbs. (1,469 g)	
GH-702-K	2,200 lbs. (1,000 kg)	197°	128°	1.07 (27.2)		1.46 (37.2)	3.30 (84)	0.63 (16)	1.81 (46)	2.09 (53)	0.98 (25)	6.57 (167)	2.13 (54)	2.05 (52)	3.54 (90)	5.75 lbs. (2,608 g)	

UNIT: inch (metric mm)

Series 70305

Model	Cross Ref.: DE-STA-CO	Holding Capacity	Arm Opens	Handle Opens
GH-70305	503-M	1,100 lbs. (500 kg)	214°	134°
GH-70310	503-MB			
GH-70315	503-MLB			
GH-70505	505-M	2,200 lbs. (1,000 kg)	206°	130°
GH-70510	505-MB			
GH-70515	505-MLB			
GH-70605	506-M	4,400 lbs. (2,000 kg)	206°	130°
GH-70610	506-MB			
GH-70615	506-MLB			



GH-70305
GH-70505
GH-70605



GH-70310
GH-70510
GH-70610



GH-70315
GH-70515
GH-70615

Model	Ø A	B	C	D	D1	E	F	G	H	K	K1	L	Weight
GH-70305	0.69 (17.5)	4.9 (125)	0.19 (4.8)	-	-	0.39 (10)	1.25 (31.8)	1.57 (40)	0.59 (15)	-	-	2" (51)	1.68 lbs. (760 g)
GH-70310				0.79 (20)	-					1.14 (29)	-		1.87 lbs. (850 g)
GH-70315				1.97 (50)	1.97 (50)					-	1.77 (45)		2.07 lbs. (940 g)
GH-70505	0.87 (22.2)	4.9 (125)	0.19 (4.8)	-	-	0.48 (12.3)	1.59 (40.3)	2.24 (57)	1.02 (26)	-	-	2.87 (73)	2.93 lbs. (1,330 g)
GH-70510				1.10 (28)	-					1.50 (38)	-		3.28 lbs. (1,490 g)
GH-70515				2.50 (63.5)	2.50 (63.5)					-	2" (51)		3.51 lbs. (1,590 g)
GH-70605	1.06 (27)	4.9 (125)	0.25 (6.3)	-	-	0.63 (16)	1.91 (48.6)	2.93 (74.3)	1.30 (33)	-	-	3.58 (91)	5.62 lbs. (2,550 g)
GH-70610				1.30 (33)	-					2" (51)	-		6.24 lbs. (2,830 g)
GH-70615				3" (76)	3" (76)					-	2.50 (63.5)		6.50 lbs. (2,950 g)

UNIT: inch (metric mm)

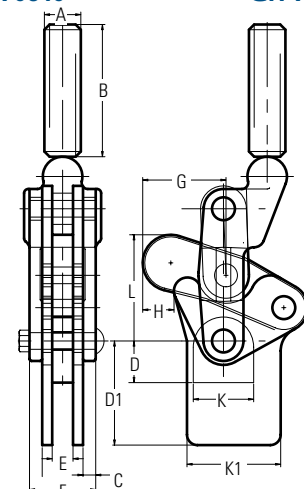

75027 & 75027-SM

- Cross Ref.: DE-STA-CO Model 527 & 527-F
- Holding Capacity: 1,000 lbs. (450 kg)
- Weight: 2.51 lbs. (1,140 g)
- Bar Opens: 195°
- Handle Moves: 65°



GH-75027



GH-75027-SM

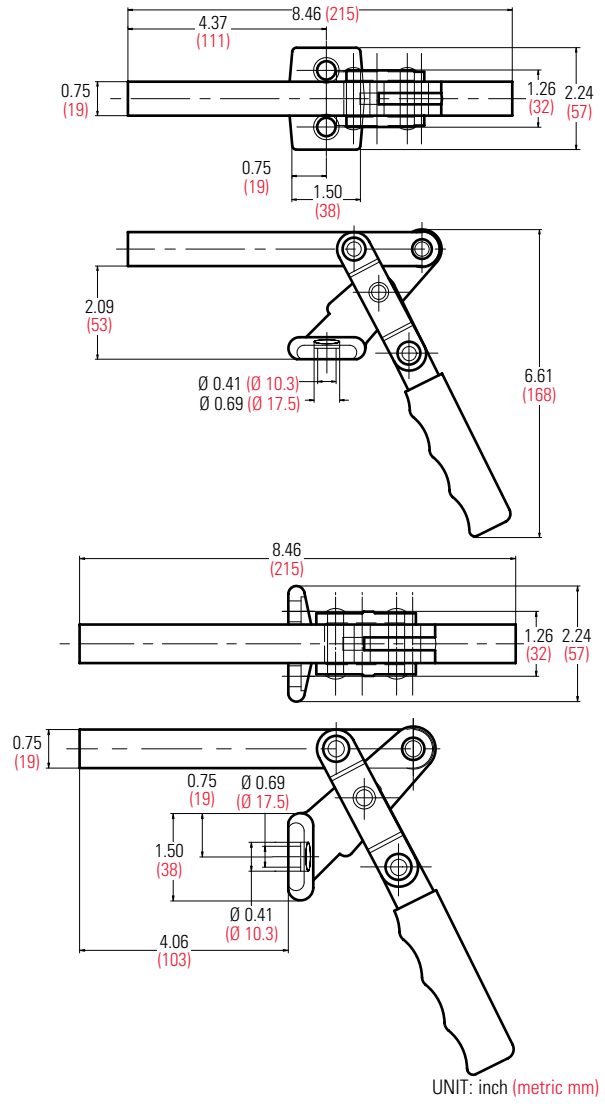

UNIT: inch (metric mm)

75048 & 75078

Cross Ref.: DE-STA-CO Model 548 & 578



GH-75048

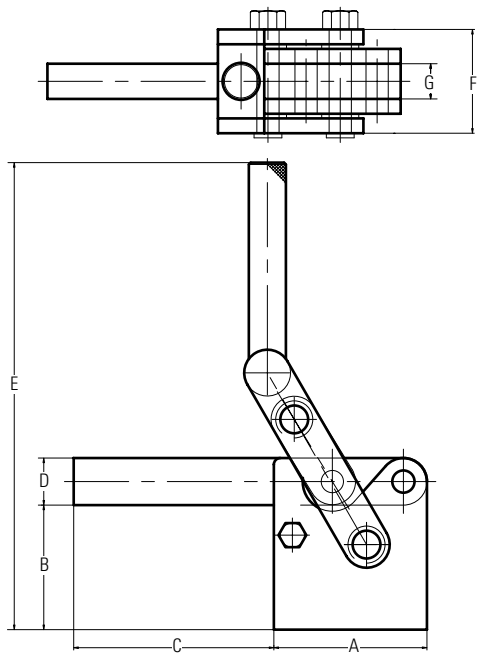

Model	Holding Capacity	Arm Opens	Handle Opens	A	B	C	D	E	F	G	Weight
GH-75048	1,500 lbs. (700 kg)	200°	110°	3.25 (82.6)	2.65 (67.2)	4.26 (108)	1" (25.4)	9.92 (252)	2.20 (56)	0.75 (19)	5.95 lbs. (2,700 g)
GH-75078	3,500 lbs. (1,600 kg)	200°	110°	4" (101.6)	2.72 (69.2)	4.63 (117.5)	1.26 (32)	10.87 (276)	2.57 (65.2)	0.87 (22.2)	9.26 lbs. (4,200 g)

UNIT: inch (metric mm)

80325 & 80325-SS

- Cross Ref.: DE-STA-CO Model 325 & 325-SS
- Holding Capacity: 750 lbs. (340 kg)
- Weight: 1.10 lbs. (500 g)
- Handle Opens: 50°
- Jaw Opens: 90°
- Spindle Supplied
- **Stainless Steel Model GH-80325-SS available**

The bottom jaw is designed to be welded to container or cover. The forged jaw swings 90° for easy job loading. 1/2-13 Hex spindle supplied.



GH-80325

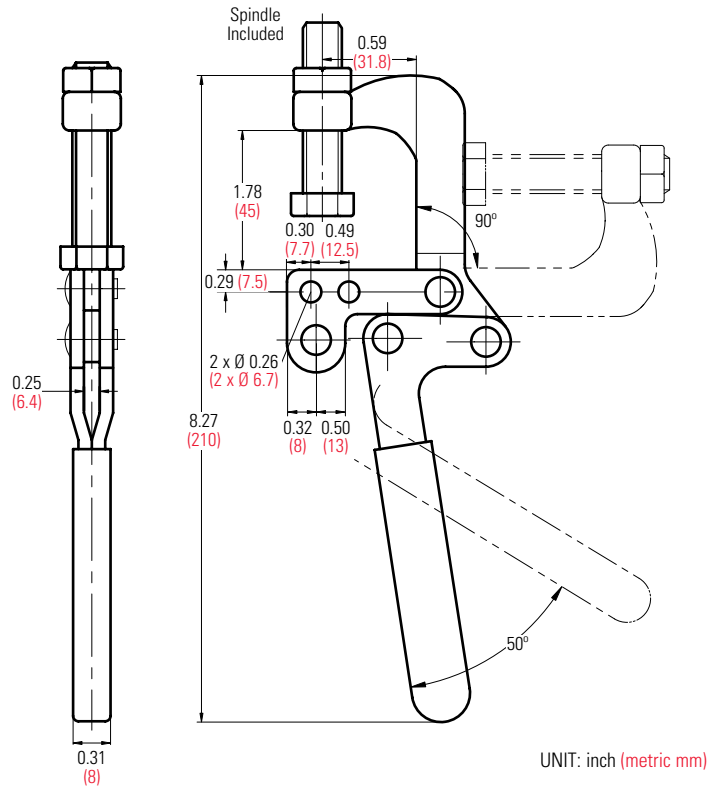

These fast acting air clamps use standard toggle clamps as the basic platform. 1/8 NPT port is standard. Maximum air pressure allowed in the cylinder is 140 PSI.

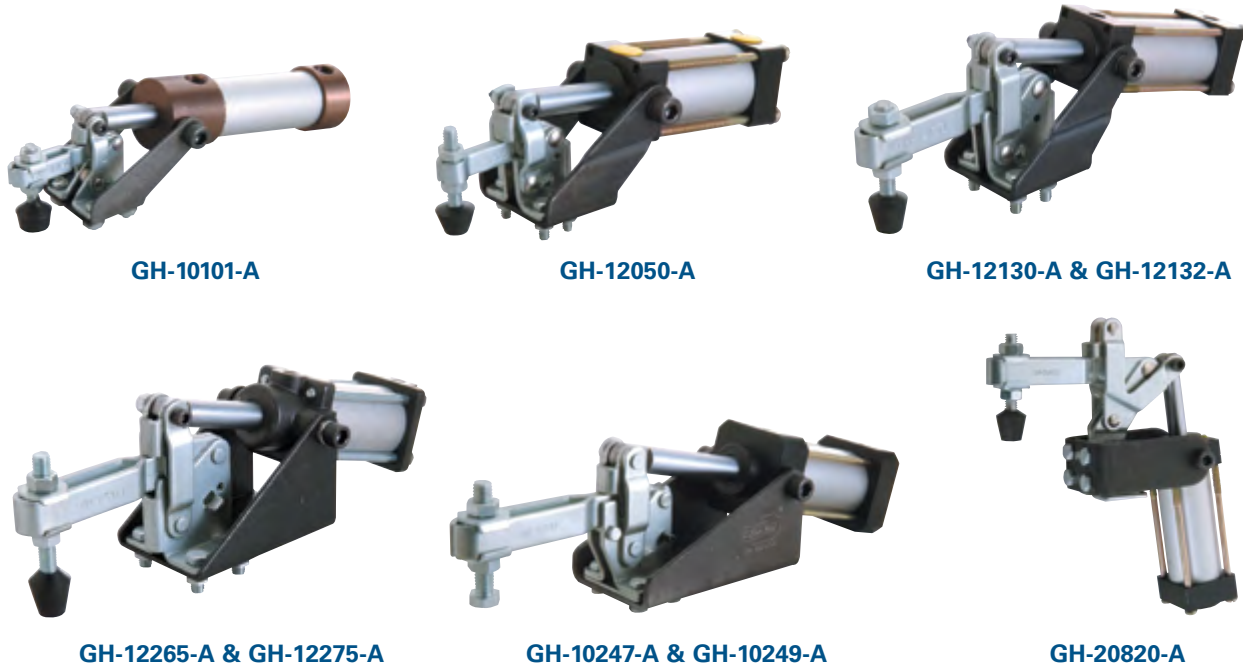

Specifications

Model	Basic Model	Holding Capacity	Spindle Supplied	Bar Opens	Cylinder Bore	Cylinder Stroke
GH-10101-A	GH-101-A	150 lbs. (68 kg)	GH-FC-10138	82°	0.78 (20)	1.24 in ² (31.4 mm ²)
GH-12050-A	GH-12050	200 lbs. (90 kg)	GH-FC-14134	95°	1.18 (30)	2.78 in ² (70.7 mm ²)
GH-12130-A	GH-12130	350 lbs. (160 kg)	GH-FC-56212	92°	1.18 (30)	2.78 in ² (70.7 mm ²)
GH-12132-A	GH-12132	350 lbs. (160 kg)	GH-FC-56212	92°	1.18 (30)	2.78 in ² (70.7 mm ²)
GH-12265-A	GH-12265	600 lbs. (272 kg)	GH-FC-38312	95°	1.57 (40)	4.94 in ² (125.6 mm ²)
GH-12275-A	GH-12275	600 lbs. (272 kg)	GH-FC-38312	95°	1.57 (40)	4.94 in ² (125.6 mm ²)
GH-10247-A	GH-10247	800 lbs. (364 kg)	GH-FC-12300	95°	2 (50)	7.73 in ² (196.3 mm ²)
GH-10249-A	GH-10249	800 lbs. (364 kg)	GH-FC-12300	95°	2 (50)	7.73 in ² (196.3 mm ²)
GH-20820-A	GH-20820	350 lbs. (160 kg)	GH-FC-56212	90°	1.18 (30)	2.78 in ² (31.4 mm ²)

UNIT: inch (metric mm)

Dimensions

Model	A	B	C	Ø D	E	F	G	H
GH-10101-A	0.94 (23.8)	0.20 (4.8)	0.63 (15.9)	0.13 (4.4)	1.60 (40.7)	0.69 (17.5)	0.94 (24)	6.63 (168.5)
GH-12050-A	1.06 (27)	0.25 (6.3)	0.50 (12.7)	0.20 (5.2)	2.19 (55.7)	1.06 (27)	1.38 (35)	7.28 (185)
GH-12130-A	1.26 (32)	0.39 (10)	0.75 (19)	0.28 (7.1)	2.97 (75.4)	1.33 (33.8)	2.68 (68)	9.31 (236.5)
GH-12132-A	1.26 (32)	0.39 (10)	0.75 (19)	0.28 (7.1)	2.97 (75.4)	1.35 (34.2)	3.47 (88.2)	10.24 (260)
GH-12265-A	1.78 (45.2)	0.37 (9.5)	1.25 (31.8)	0.33 (8.3)	3.69 (93.7)	1.75 (44.2)	3.47 (88.2)	15.43 (392)
GH-12275-A	1.78 (45.2)	0.37 (9.5)	1.25 (31.8)	0.33 (8.3)	3.69 (93.7)	1.75 (44.2)	3.47 (88.2)	11.89 (302)
GH-10247-A	1.78 (45.2)	0.74 (19)	1.25 (31.8)	0.33 (8.3)	4.33 (110)	2.18 (55.3)	4.52 (114.8)	16.02 (407)
GH-10249-A	1.78 (45.2)	0.74 (19)	1.25 (31.8)	0.33 (8.3)	4.33 (110)	2.18 (55.3)	4.52 (114.8)	16.02 (407)
GH-20820-A	0.98 (25)	0.65 (17)	0.63 (16)	0.28 (7)	7.68 (195)	2.75 (70)	2.36 (60)	6.50 (165)

UNIT: inch (metric mm)

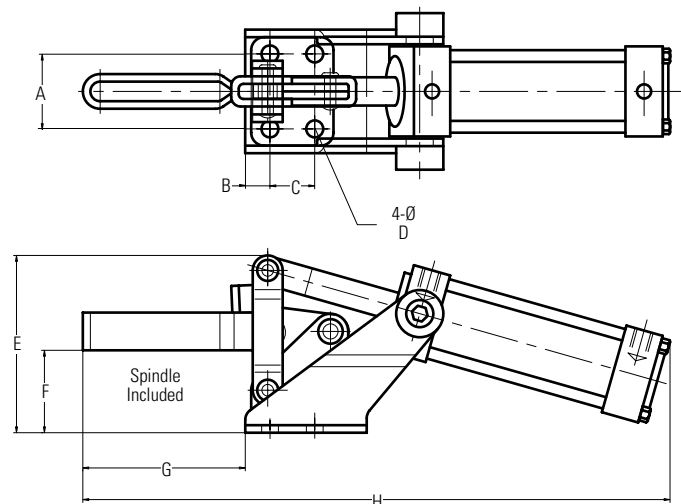



GH-36301-A

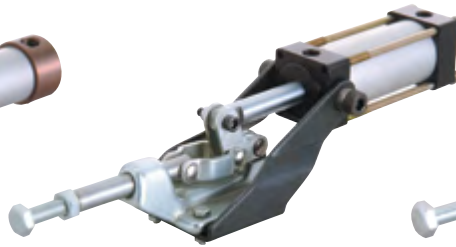

GH-36003-A



GH-36330-A

Specifications

Model	Basic Model	Holding Capacity	Spindle Supplied	Cylinder Bore	Cylinder Stroke
GH-36301-A	GH-301-A	100 lbs. (454 kg)	GH-SA-08034	0.75 (20)	1.24 in ² (3.14 cm ²)
GH-36003-A	GH-36003	600 lbs. (273 kg)	GH-SA-56200	1.18 (30)	2.78 in ² (7.07 cm ²)
GH-36330-A	GH-36330	2,500 lbs. (1,136 kg)	GH-SA-38300	1.57 (40)	4.94 in ² (12.56 cm ²)

UNIT: inch (metric mm)

Dimensions

Model	A	B	Ø C	D	E	F	G	H	J	K
GH-36301-A	0.63 (15.9)	0.25 (6.4)	0.17 (4.4)	1.27 (32.2)	1.57 (40)	0.63 (15.9)	-	0.47 (12)	0.54 (13.6)	7.36 (187)
GH-36003-A	1.31 (33.3)	0.44 (11.1)	0.22 (5.6)	2.28 (58)	2.74 (69.5)	1.44 (36.5)	-	0.78 (19.7)	1.09 (27.7)	9.84 (250)
GH-36330-A	1.63 (41.3)	0.63 (15.9)	0.34 (8.7)	2.03 (51.5)	3.30 (84)	1.37 (34.9)	1.63 (41.3)	1.18 (30)	1.05 (26.6)	13.66 (347)

UNIT: inch (metric mm)

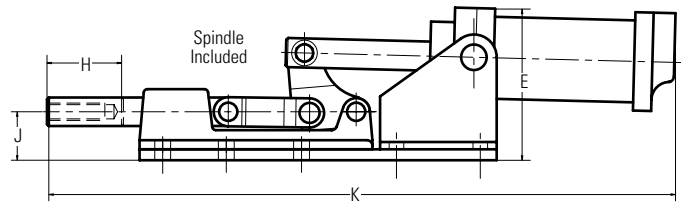
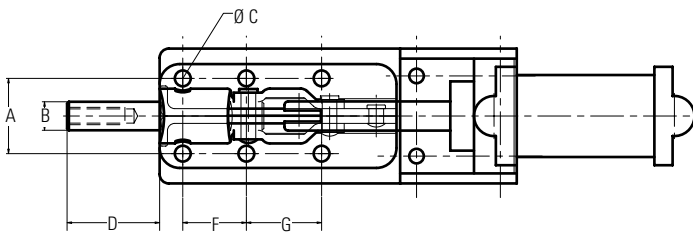

Yoke Assemblies

Hold two workpieces, or long pieces of fabric or metal. The yokes have spring loaded, extra-wide spindles that provide strong, no-mar holding power that can be adjusted to accommodate varying material thicknesses and sizes.



GH-YP-3145 Yoke attached to GH-304-E Clamp (Sold separately)

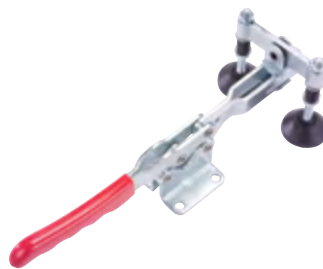

GH-YP-3130 Yoke attached to GH-20235 Clamp (Sold separately)



GH-YP-3160 Yoke attached to GH-12265 Clamp (Sold separately)

Plastic Pad Part No.	A	L
GH-YP-3130	5/16-18	3" (76.2)
GH-YP-3145	5/16-18	4.5 (114.3)
GH-YP-3160	5/16-18	6" (152.4)
GH-YP-3730	3/8-16	3" (76.2)
GH-YP-3745	3/8-16	4.5 (114.3)
GH-YP-3760	3/8-16	6" (152.4)

UNIT: inch (metric mm)

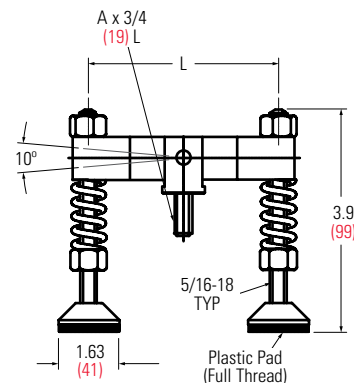

UNIT: inch (metric mm)

Adjustable Spindle Assemblies

Flat Cushion Tip Bonded Neoprene Cap

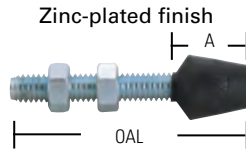

Part No.	Thread	OAL	A
GH-FC-10138	10-24	1-7/16	7/16
GH-FC-14134	1/4-20	1-7/8	1/2
GH-FC-14218	1/4-20	2-1/8	1/2
GH-FC-56212	5/16-18	2-1/2	3/4
GH-FC-56300	5/16-18	3	3/4
GH-FC-38312	3/8-16	3-1/2	1
GH-FC-38412	3/8-16	4-1/2	1
GH-FC-12334	1/2-13	3-3/4	1

Standard Adjustable

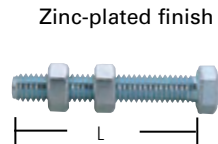

Part No.	Thread	L
GH-SA-08034	8-32	3/4
GH-SA-10118	10-24	1-1/8
GH-SA-14112	1/4-20	1-1/2
GH-SA-14134	1/4-20	1-3/4
GH-SA-56200	5/16-18	2
GH-SA-56212	5/16-18	2-1/2
GH-SA-38300	3/8-16	3
GH-SA-38400	3/8-16	4
GH-SA-12300	1/2-13	3
GH-SA-12412	1/2-13	4-1/2
GH-SA-58500	5/8-11	5

Cone Cushion Tip Bonded Neoprene Cap

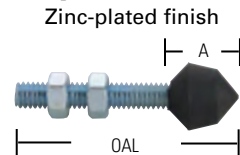

Part No.	Thread	OAL	A
GH-CC-10138	10-24	1-3/8	1/2
GH-CC-14134	1/4-20	1-3/4	3/4
GH-CC-14218	1/4-20	2-1/8	3/4
GH-CC-56212	5/16-18	2-1/2	13/16
GH-CC-38312	3/8-16	3-1/2	1

Swivel Foot Adjustable Spindle Assemblies

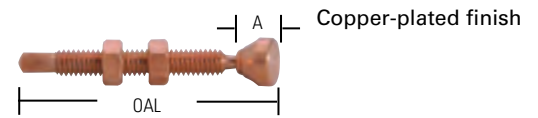

Part No.	Thread	OAL	A
GH-SF-14214	1/4-20	2-1/4	3/8
GH-SF-56234	5/16-18	2-3/4	3/8
GH-SF-38200	3/8-16	2	3/8
GH-SF-38300	3/8-16	3	7/16
GH-SF-12300	1/2-13	3	7/16
GH-SF-12400	1/2-13	4	1/2

Flanged Washers for U-Bar Clamps



Part No.	Description
GH-FW-080	For 8 spindle
GH-FW-100	For 10 spindle
GH-FW-140	For 1/4 spindle
GH-FW-516	For 5/16 spindle
GH-FW-380	For 3/8 spindle
GH-FW-120	For 1/2 spindle
GH-FW-580	For 5/8 spindle

Neoprene Caps

Slips on standard adjustable spindle heads.



Part No.	Description
GH-NC-140	For 1/4 spindle
GH-NC-516	For 5/16 spindle
GH-NC-380	For 3/8 spindle
GH-NC-120	For 1/2 spindle

Bolt Retainers



Part No.	Description
GH-BR-140	For 1/4 spindle
GH-BR-516	For 5/16 spindle
GH-BR-380	For 3/8 spindle
GH-BR-120	For 1/2 spindle
GH-BR-580	For 5/8 spindle



PART NO.	PAGE	PART NO.	PAGE	PART NO.	PAGE	PART NO.	PAGE
101-A	1	10249-A	42	22105	12	70305	39
101-AI	1	10249	8	22165	16	70310	39
101-AIT	1	10444	8	22170	16	70315	39
101-ASS	1	10448	8	22175	16	70505	39
101-AT	1	11002-B	1	22180	16	70510	39
101-B	4	12002-B	1	22185	16	70515	39
101-J	9	12130-SM	6	22190	16	70605	39
101-JS	9	12050-A	42	22195	16	70610	39
102-B	4	12050-HB	3	22200	16	70615	39
106-B	5	12050-SM	3	22235	17	75027-SM	40
200-W	19	12050-SS	3	22502-B	12	75027	40
200-WH	19	12050-U	3	25382	18	75048	40
200-WL	19	12050-UL	3	25383	17	75078	40
200-WLH	19	12050	3	30250	25	80325-SS	41
201-A	10	10250	8	30282	22	80325	41
201-AI	10	12055	3	30290	23	BR-120	44
201-AL	10	12060	3	30292	23	BR-140	44
201-AR	10	12065	3	30450	25	BR-380	44
201-ASS	10	12070	3	30509	27	BR-516	44
201-B	13	12075	3	30519	27	BR-580	44
201-BHB	13	12080	3	30607	24	CC-10138	44
201-BI	13	12085	3	30609	27	CC-14134	44
201-BS	13	12130-A	42	30619	27	CC-14218	44
201-BSI	13	12130-HB	6	36003-A	43	CC-38312	44
201-BSM	13	12130-SS	6	36003	23	CC-56212	44
201-BSS	13	12130	6	36006	21	FC-10138	44
201-I	10	12131	6	36010	24	FC-12334	44
201-L	10	12132-A	42	36012	24	FC-14134	44
201-R	10	12132	6	36020	23	FC-14218	44
201-SS	10	12133	6	36060	24	FC-38312	44
201	10	12135	6	36070	21	FC-38412	44
202-F	14	12136	6	36092	22	FC-56212	44
202-FL	14	12137	6	36202	26	FC-56300	44
203-F	14	12138	6	36204-SS	26	FW-080	44
203-FL	14	12140	6	36204	26	FW-100	44
204-G	20	12141	6	36205	26	FW-120	44
204-GB	20	12142	6	36224	26	FW-140	44
204-GBL	20	12143	6	36225	26	FW-380	44
204-GBLH	20	12145	6	36301-A	43	FW-516	44
204-GL	20	12146	6	36330-A	43	FW-580	44
220-VH	19	12147	6	36330	25	NC-120	44
220-WLH	19	12148	6	40323-LUB	29	NC-140	44
225-D	15	12205	5	40323-LUBSS	29	NC-380	44
225-DHB	15	12265-A	42	40323-R	28	NC-516	44
225-DI	15	12265-SS	7	40323-SS	28	SA-08034	44
225-DSM	15	12265	7	40323	28	SA-10118	44
225-DSS	15	12270	7	40324-R	33	SA-12300	44
301-A	21	12275-A	42	40324	32	SA-12412	44
301-B	21	12275	7	40334-R	33	SA-14112	44
302-D	22	12280	7	40334	32	SA-14134	44
302-F	22	12285	7	40341-LUB	29	SA-38300	44
302-FSS	22	12290	7	40341-LUBSS	29	SA-38400	44
303-EK	25	12295	7	40341-R	29	SA-56200	44
304-C	26	12300	7	40341-SS	28	SA-56212	44
304-E	26	12305	7	40341	28	SA-58500	44
304-H	26	12310	7	40344-R	33	SF-12300	44
305-C	26	12315	7	40344	32	SF-12400	44
305-E	26	12320	7	40370-LP	31	SF-14214	44
305-H	26	13002-B	1	40370-R	30	SF-38200	44
431-LUB	29	13005-HB	2	40370	30	SF-38300	44
431-LUBSS	29	13005-SM	2	40371-LP	34	SF-56234	44
431-R	29	13005-SS	2	40371	34	YP-3130	43
431-SS	28	13005	2	40380	31	YP-3145	43
431	28	13007-SM	2	40820	32	YP-3160	43
451-LP	34	13007	2	40840	32	YP-3730	43
451-LPSS	34	13008	2	40870	32	YP-3745	43
451-SS	34	20235-SS	18	43101-LP	34	YP-3760	43
451	34	20235	18	43101	34		
452-LP	34	20236	18	43110	35		
452-LPSS	34	20300	11	43120	35		
452-SS	34	20752-B	12	43150	35		
452	34	20800-SS	11	43160	35		
701-C	39	20800	11	43810-LP	34		
701-D	39	20820-A	42	43810	34		
701-K	39	20820	14	50350	36		
702-C	39	21383	16	50360	36		
702-D	39	21502-B	12	50380	36		
702-K	39	22005	10	50385	36		
10101-A	42	22010	10	50450	37		
10247-A	42	22025	10	60130	38		
10247	8	22030	10	60131	38		
10248	8	22100	12	61352	37		



Strong Hand Tools®

Quick Acting Welding Clamps, Magnets, Pliers, and Vises allow you to create accurate fit-ups quickly, safely and efficiently.



BuildPro® Welding Tables

Affordable, Modular Welding Tables with the plate + hole + slot system for complete flexibility in fixturing.

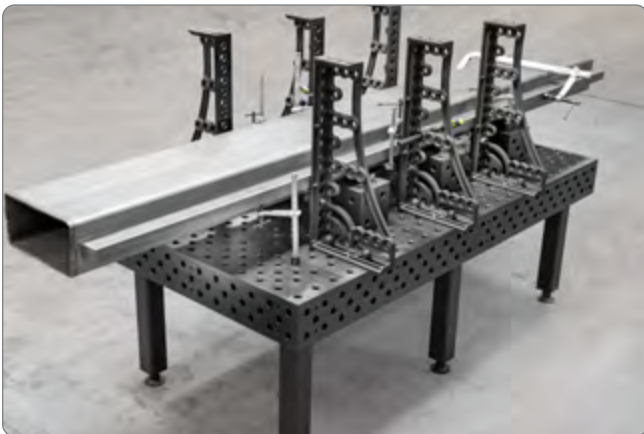

Alpha 28 Welding Tables

Precision Horizontal and vertical fixturing with unlimited possibilities.



Valtra® Machine Parts

Handwheels, handles, clamps, levers, and threaded fasteners for manufacturing, and MRO. Stock or custom.



*See many more problem solving tools @
StrongHandTools.com*

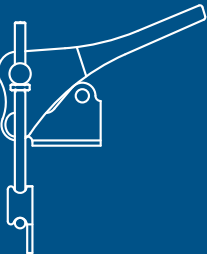
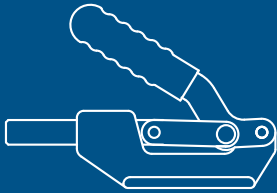
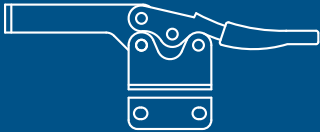
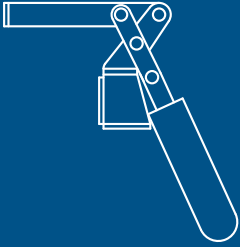
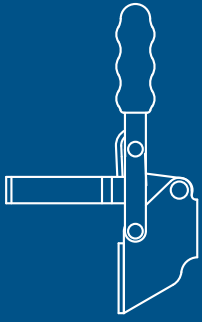

Good Hand Inc.

TOLL FREE
(800) 989-5244

TEL
(562) 949-8625

FAX
(562) 949-4875

ADDRESS
8750 Pioneer Blvd.,
Santa Fe Springs, CA 90670

WEB
www.goodhandinc.com

E-MAIL
sales@valtrainc.com

QUALITY • DIVERSITY • ECONOMY